

# LOCOMOTIVE BOILERS AND ENGINES

A PRACTICAL TREATISE ON LOCOMOTIVE BOILER AND ENGINE  
DESIGN, CONSTRUCTION, AND OPERATION

BY

LLEWELLYN V. LUDY, M.E.

PROFESSOR OF EXPERIMENTAL ENGINEERING, PURDUE  
UNIVERSITY

AMERICAN SOCIETY OF MECHANICAL ENGINEERS

ILLUSTRATED

AMERICAN TECHNICAL SOCIETY

CHICAGO

1920

Copyright 1909, 1913, 1914, 1917, 1920, by

AMERICAN TECHNICAL SOCIETY

-----

COPYRIGHTED IN GREAT BRITAIN

ALL RIGHTS RESERVED

# INTRODUCTION

OF ALL heat engines, the locomotive is probably the least efficient, principally due, no doubt, to the fact that it is subject to enormous radiation losses and to the fact that it must carry its own steam plant. However, even with these serious handicaps, the utility and flexibility of this self-contained power unit are so great that only in a comparatively few instances have the railroads been able to see their way clear to adopt electric locomotives and, even in these cases, only for relatively small distances.

Stephenson's "Rocket" was in its day considered a wonder and when pulling one car was capable of a speed of probably 25 miles per hour. The fact that our present-day "moguls" can draw a heavy limited train at 80 miles per hour gives some indication of the theoretical and mechanical developments which have made this marvelous advance possible.

In the development of any important device, what seem to us now as little things often have contributed largely to its success-- nay more, have even made that success possible. No locomotive had been at all successful until Stephenson hit upon the idea of "forced draft" by sending the exhaust steam out of the smokestack. This arrangement made possible the excessive heat of the furnace necessary to form steam rapidly enough to satisfy the demand of the locomotive. From that time on the progress made was merely a question of taking advantage of improvements in workmanship and design and later of such valuable principles as compound expansion, valve gearing, etc.

The historical development of the locomotive and the discussion of the theoretical and mechanical improvements, which have made it what it is today, are exceedingly important to the engineer and of great interest to the layman. The practical side of the subject has been exceptionally well handled in this book and will be found profitable to all readers.

# CONTENTS

	page
<b><u>Introduction</u></b>	<b>3</b>
<b><u>Contents</u></b>	<b>4</b>
<b><u>Historical development of locomotive</u></b>	<b>10</b>
Trevithick's locomotive	10
The Rocket	11
Best Friend of Charleston	12
Camel-Back	12
Hayes 10-Wheeler	13
The Daniel Nason	13
The Reuben Wells	14
American type locomotive	15
Compound locomotives	16
<b><u>Classification of locomotives</u></b>	<b>18</b>
Whyte system	18
Mogul type	19
Consolidation type	21
Atlantic type	22
Pacific type	22
Cole four-cylinder balanced compound locomotive	25
Mallet articulated compound locomotive	26
Cross-compound locomotive	37
<b><u>Action of steam in operating locomotive</u></b>	<b>40</b>
General course of steam	40
Steam enters steam chest	40
Steam enters cylinder	40
Steam in cylinder	41
Steam after leaving cylinder	41
<b><u>Locomotive boilers</u></b>	<b>42</b>
Classification of boilers as to form	42
Classification of boilers as to fire-box used	42
Flues	47
Stay-bolts	48
Grates	53
Ash pans	54
Brick arches	55



	<b>page</b>
Smoke-box and front end arrangement	<b>57</b>
Steam or branch pipes	<b>57</b>
Exhaust nozzle	<b>57</b>
Netting	<b>57</b>
Diaphragm	<b>57</b>
Draft pipes	<b>57</b>
Draft	<b>57</b>
Exhaust nozzles	<b>58</b>
Stack	<b>60</b>
Rate of combustion	<b>61</b>
Spark losses	<b>63</b>
High steam pressures	<b>63</b>
Effect of different pressures upon boiler performance	<b>63</b>
Effect of different pressures upon smoke-box temperatures	<b>64</b>
Heating surface	<b>65</b>
Superheaters	<b>66</b>
Locomotive boiler design	<b>76</b>
Boiler capacity	<b>79</b>
Locomotive engine	<b>82</b>
Lead	<b>82</b>
Outside lap	<b>82</b>
Inside clearance	<b>82</b>
<b>Valve motion</b>	<b>83</b>
Requirements	<b>83</b>
Stephenson valve gear	<b>83</b>
Walschaert valve gear	<b>87</b>
Comparison between Stephenson and Walschaert gears	<b>89</b>
Valves	<b>92</b>
Valve friction	<b>94</b>
<b>Running gear</b>	<b>96</b>
Wheels	<b>96</b>
Axles	<b>101</b>
Crank pins	<b>102</b>
Locomotive frames	<b>103</b>
Cylinder and saddle	<b>105</b>
Piston and rods	<b>105</b>
Crossheads and guides	<b>107</b>

	page
Connecting or main rods	108
Parallel or side rods	109
Locomotive trucks	110
Tender	114
Locomotive stokers	115
<b><u>Design of parts of engine</u></b>	<b>118</b>
Axles	118
Crank pins	122
Piston rods	124
Frames	125
Cylinders	126
Locomotive rating	130
<b><u>Locomotive appliances</u></b>	<b>133</b>
Safety valves	133
Injector	135
Whistle	137
Steam gauges	139
Water gauges	139
Blower	139
Throttle valve	140
Dry pipe	140
Lubricator	140
Air brake and signal equipment	141
<b><u>Railway signaling</u></b>	<b>143</b>
Whistle signals	143
Bell cord signals	144
Movable signals	144
Train signals	145
Fixed signals	149
Block system	151
<b><u>Locomotive operation</u></b>	<b>154</b>
Running	154
Inspection	157
Cleaning	157
Repairs	157
Emergencies	157
<b><u>Train rules</u></b>	<b>159</b>

	page
<b>Time tables</b>	<b>162</b>
<b>Locomotive troubles and remedies</b>	<b>163</b>
Distinctive features of locomotive	163
Pounds	163
Steam waste	164
Care of boiler	165
Drifting	166
Fuel waste	167
<b>Locomotive breakdowns</b>	<b>168</b>
Possible Causes	168
Derailments	168
Explosion of boiler	169
Collapse of flue	169
Disconnecting after breakdown	169
<b>Duties of locomotive engineer</b>	<b>171</b>
Watching his road	171
Care of locomotive	175

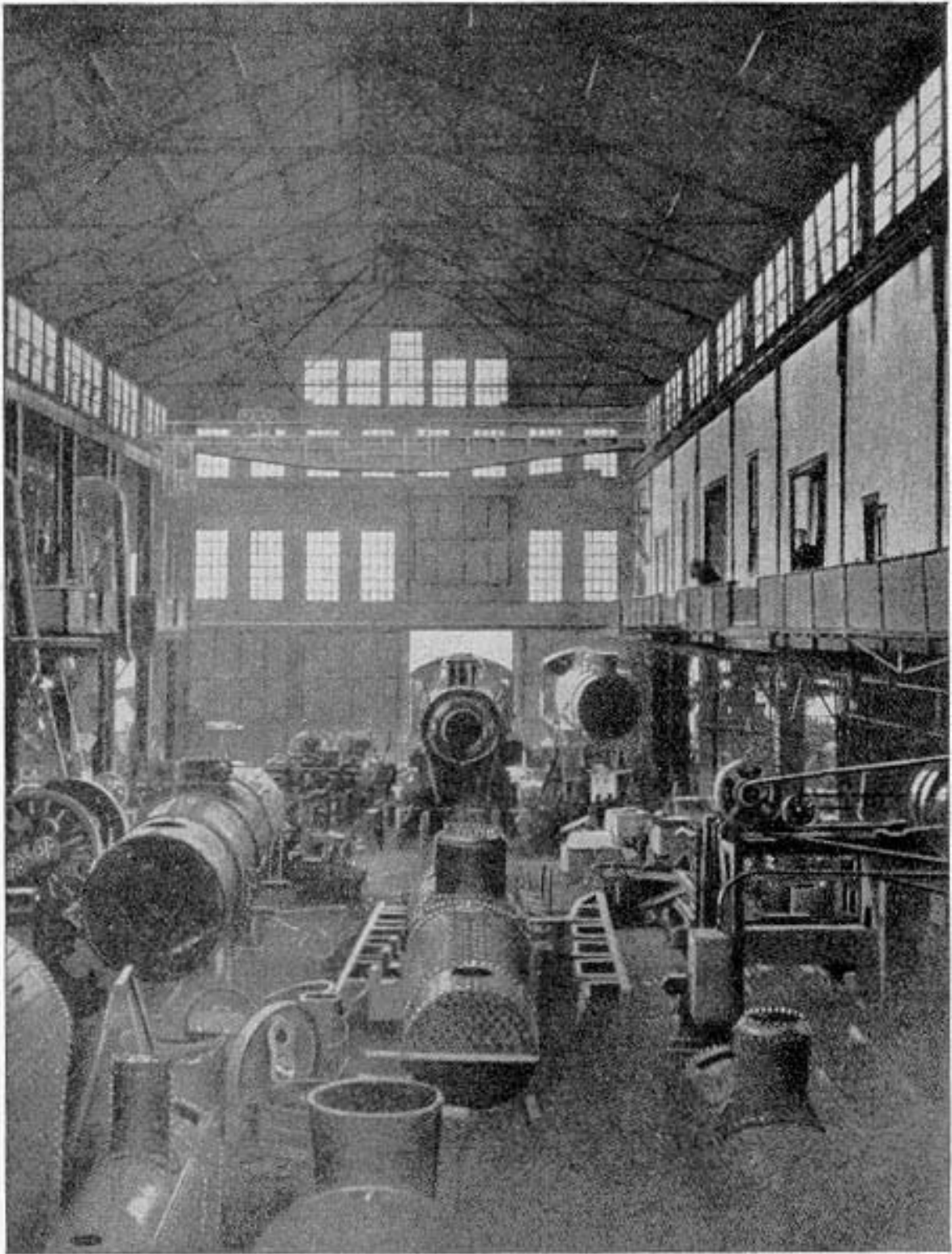

**ROD LOCOMOTIVE ERECTING ROOM**  
*Courtesy of Lima Locomotive Corporation, Lima, Ohio*

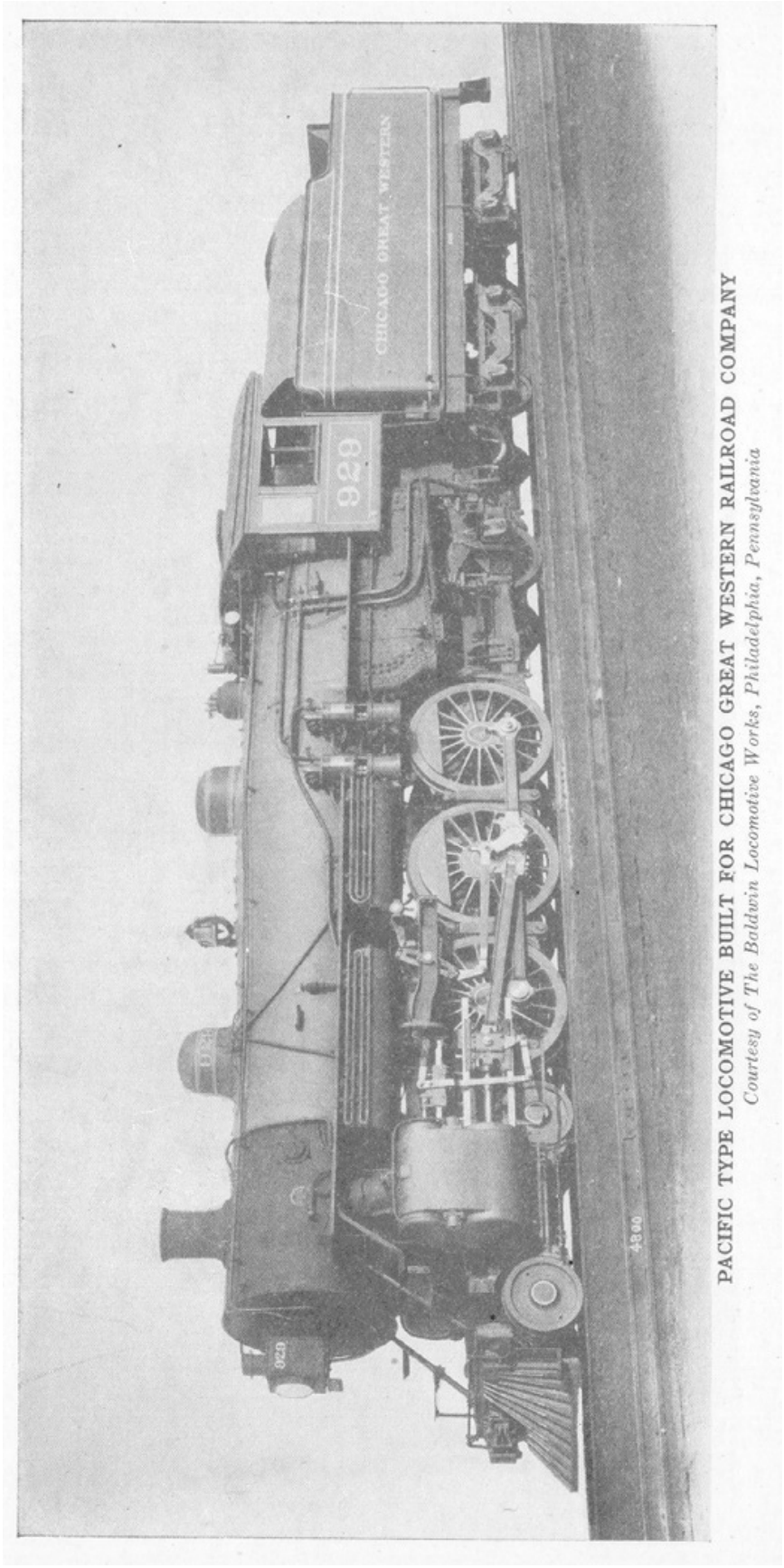

PACIFIC TYPE LOCOMOTIVE BUILT FOR CHICAGO GREAT WESTERN RAILROAD COMPANY  
*Courtesy of The Baldwin Locomotive Works, Philadelphia, Pennsylvania*

# LOCOMOTIVE BOILERS AND ENGINES

## PART I

### HISTORICAL DEVELOPMENT OF THE LOCOMOTIVE

The first locomotive engine designed to run upon rails was constructed in 1803, under the direction of Richard Trevithick, a Cornish mine captain in South Wales. Though crudely and peculiarly made, it possessed all of the characteristics of the modern locomotive with the exception of the multi-tubular boiler. The locomotive had a return-flue boiler 60 inches long, and two pairs of driving wheels - each 52 inches in diameter. The power was furnished by one cylinder, 54 inches long and 8 inches in diameter.

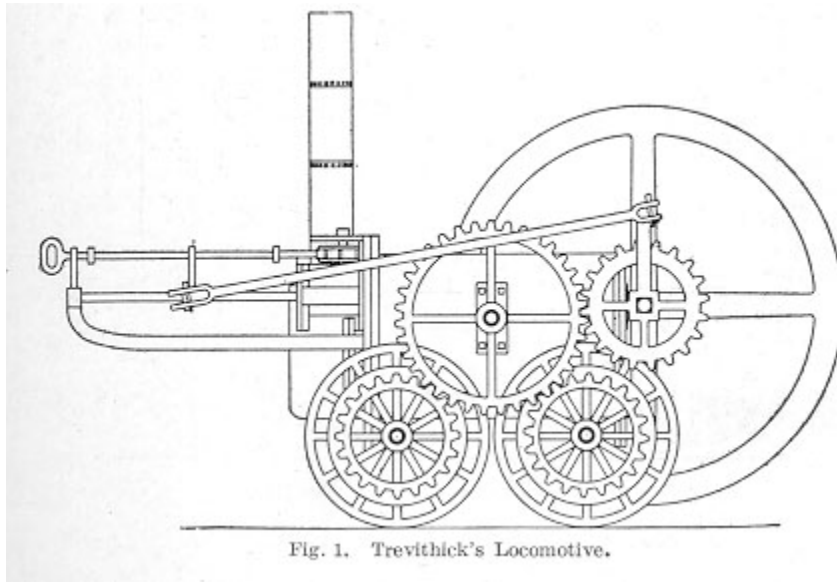

The exhaust steam from the cylinder was conducted to the smoke-stack where it aided in creating a draft on the fire. This engine, shown in [Fig. 1](#), made several trips of nine miles each, running about five miles per hour and carrying about two tons. Although the machine was a commercial failure, yet from a mechanical standpoint, it was a great success.

After the development of the Trevithick locomotive, numerous experiments were tried out and many engineers were working on a new design. As a consequence, many very crude but interesting locomotives were developed. The principal objection raised against the most of them was in reference to the complicated parts of the mechanism. Having had no previous experience to direct them, they failed to see that the fewer and simpler the parts of the machine, the better. It was not until about 1828, when the *Rocket*, as shown in [Fig. 2](#), was built under the supervision of Robert Stephenson, that anything of note was accomplished. The *Rocket*, in a competition speed test, without carrying any load, ran at the rate of 29½ miles per hour. With a car carrying thirty passengers, it attained a speed of 28 miles per hour. The construction of the *Rocket* was a step in the right direction, since it contained fewer and simpler parts. It had an appearance similar to the modern locomotive, having a multitubular boiler, induced draft by means of the exhaust steam, and a direct connection between the piston rod and crank pin secured to the driving

wheel. The cylinder was inclined and proportions were very peculiar as compared with the modern locomotive, yet much had been gained by this advancement.

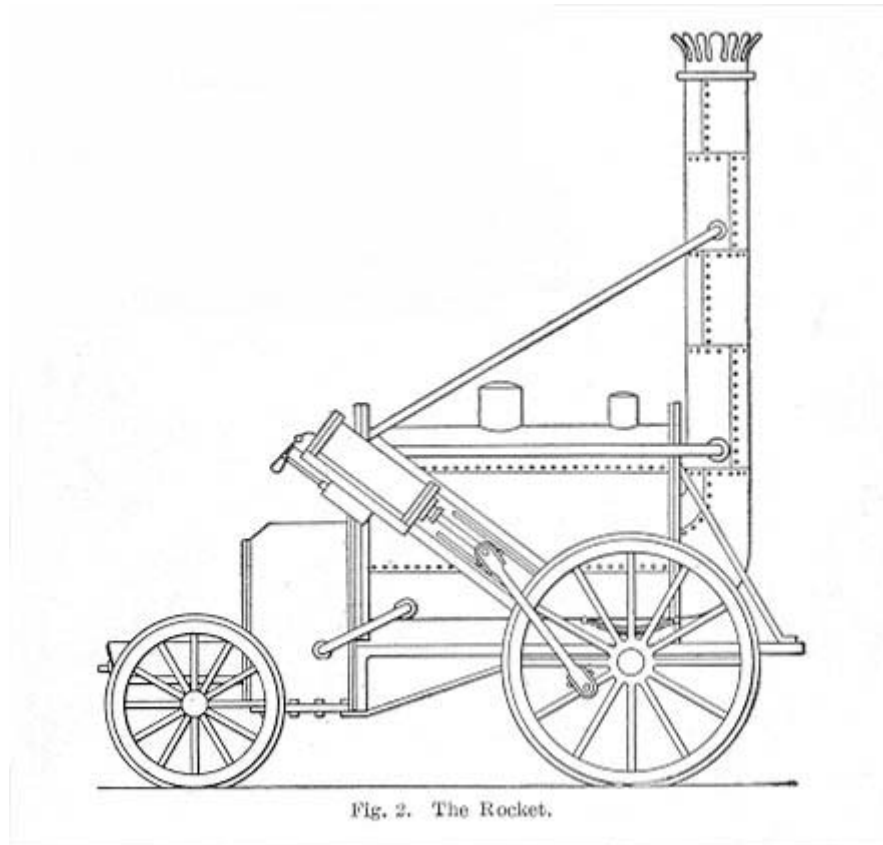

Fig. 2. The Rocket.

While these things were being accomplished in England, the fact must be noted that agitation in favor of railroad building in America was being carried on with zeal and success. Much of the machinery for operating the American railroads was being designed and built by American engineers, so it is quite generally believed that railroad and locomotive building in America would not have been very much delayed had there never been a Watt or a Stephenson.

The first railroad opened to general traffic was the Baltimore & Ohio, which was chartered in 1827, a portion being opened for business in 1830. About the same time, the South Carolina Road was built. The board of directors of this road were concerned with what kind of power to use, namely, horse-power or steam engines. After much deliberation, it was finally decided to use a steam-propelled locomotive.

The history of this period is interesting. The first steam locomotive built in America was the *Best Friend of Charleston*, illustrated in [Fig. 3](#). One year previous to the building of this locomotive, an English locomotive called *Stourbridge Lion* was imported by the Delaware-Hudson Canal Co. It was tried near Homesdale. A celebrated American engineer by the name of Horatio Allen, made a number of trial trips on this locomotive and pronounced it too heavy for the American roadbeds and bridges; so it was that the *Best Friend of Charleston*, an American locomotive constructed in 1830, gave the first successful service in America. The *Best Friend of Charleston* was a four-wheeled engine having two inclined cylinders. The wheels were constructed of iron hubs with wooden spokes and wooden fellows, having iron tires shrunk on in the usual way. A vertical



boiler was employed and rested upon an extension of the frame which was placed between the four wheels. The cylinders, two in number, were each 6 inches in diameter and had a common stroke of 16 inches. The wheels were 4½ feet in diameter. The total weight of the locomotive was about 10,000 pounds. Assuming power by present methods, it would develop about 12 horse-power while running at a speed of 20 miles per hour and using a steam pressure of 50 pounds.

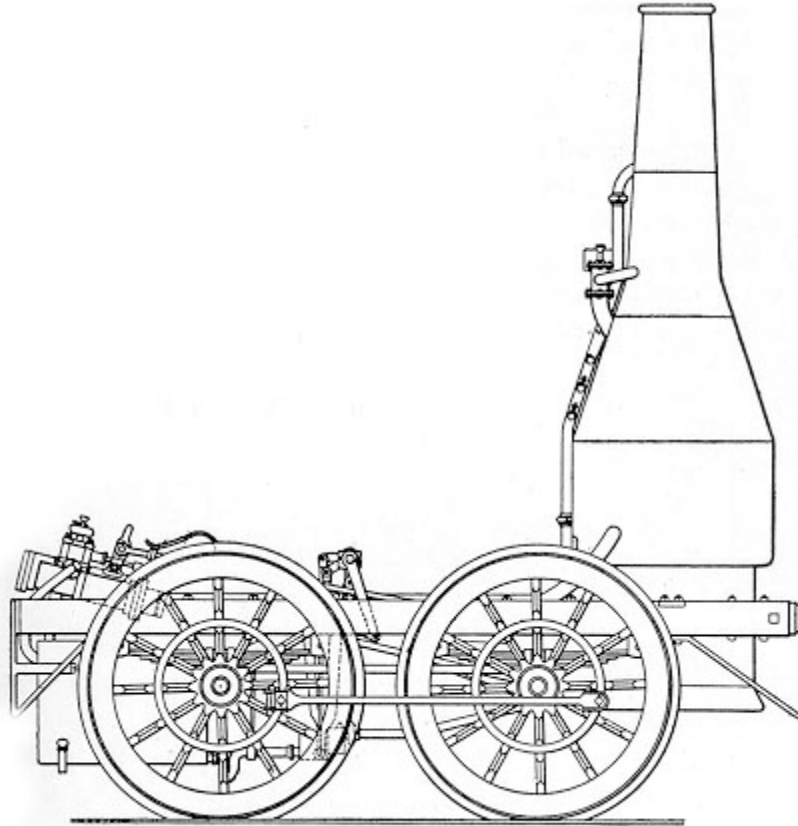

Fig. 3. The Best Friend of Charleston.

The Baltimore & Ohio Railroad was the leader for a number of years in the development of the locomotive. Among the earlier designs brought out by this road was an 8-wheeled engine known as the *Camel-Back*, so-called from its appearance, and frequently spoken of as the *Winans*, as its design was developed in 1844 by Ross Winans, a prominent locomotive builder of a half century ago.

The illustration shown in [Fig.4a](#) represents the *Hayes 10-Wheeler* with side rods removed, which was built after designs prepared in 1853 by Samuel J. Hayes of the B. & O. [Fig. 4b](#) is from an original drawing of one of the earlier types of the same engine and shows more of the details of construction. This locomotive is oftentimes improperly called the *Camel-Back* or *Winans* engine because of its close resemblance to the *Winans*. The name *Camel-Back*, as given to the *Winans* engine and also to the *Hayes 10-Wheeler*, was given on account of the peculiar appearance of the locomotive, which, in fact, did resemble a camel's humped back. This appearance was due to the fact that a large cab was placed on the central portion of the boiler, and also to the rapidly receding back end of the boiler. The weight of the *Hayes 10-Wheeler* is 77,100 pounds, of which 56,500 pounds are on the drivers and 20,060 pounds are on the front truck. The diameter of the



front truck wheels is 28 inches and that of the drivers, 50 inches. The fire-box is  $42\frac{1}{4}$  inches long and  $59\frac{1}{4}$  inches wide. The boiler has a total heating surface of 1,176.91 square feet, 1,098 square feet of this amount being in the flues. There are 134 tubes  $2\frac{1}{4}$  inches in diameter and 13 feet 11 inches long.

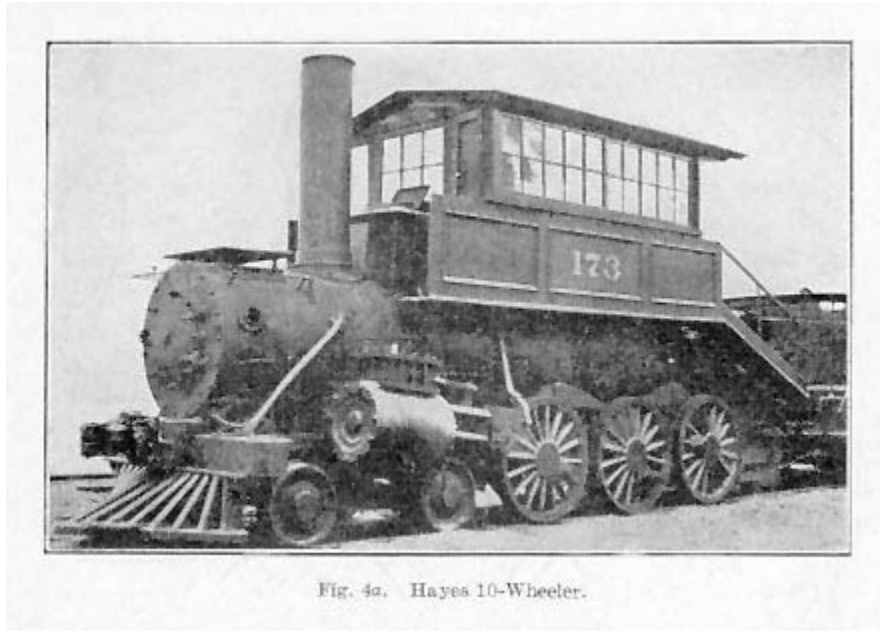

Fig. 4a. Hayes 10-Wheeler.

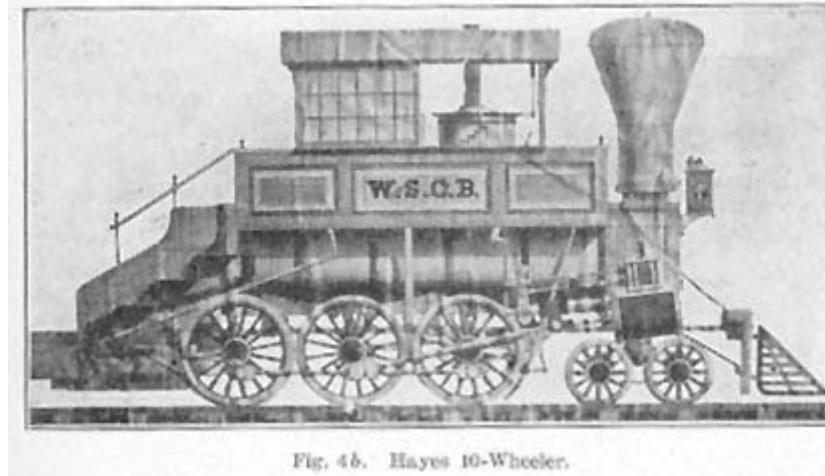

Fig. 4b. Hayes 10-Wheeler.

The Boston & Providence Railroad built several locomotives during the time the Winans locomotive was being developed. One of these, the *Daniel Nason*, illustrated in [Fig. 5](#), was built in 1858. The *Daniel Nason* weighs 52,650 pounds, has 16 by 20 inch cylinders, 54-inch driving wheels, and 30-inch truck wheels. Steam pumps were used in feeding the boiler instead of the injectors. The top members of the frame are built up of rectangular sections, while for the bottom members, 4-inch tubes are used.

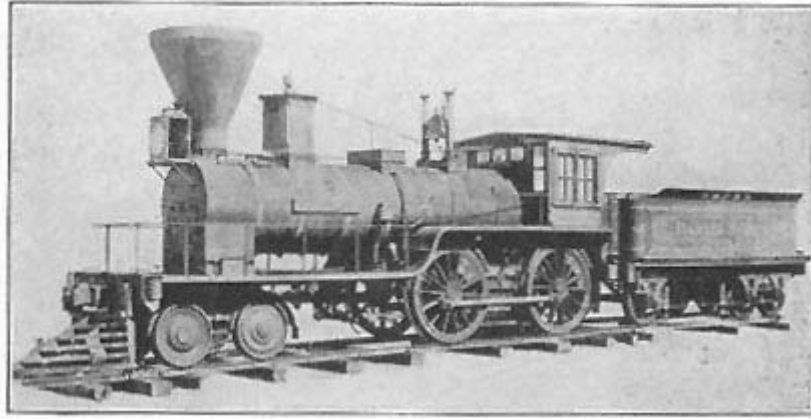

Fig. 5. The Daniel Nason.

The prevailing thought in the early development of the locomotive was, that sufficient power could not be secured by depending upon the adhesion of the drivers to the rail; as a consequence many cog locomotives were developed and used. This was true on the old Jeffersonville, Madison & Indianapolis Railroad at Madison, Indiana. A portion of the road at that point included a six per cent grade three miles long. From the opening of the road in 1848 until 1858, the grade was operated by cog locomotives. On the last-named date, there appeared a locomotive named the *Reuben Wells* which was destined to have both a very interesting and successful career.

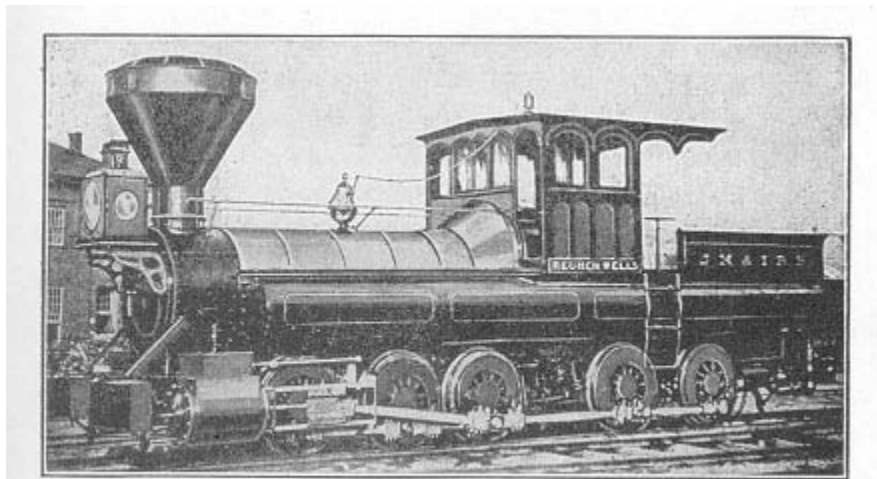
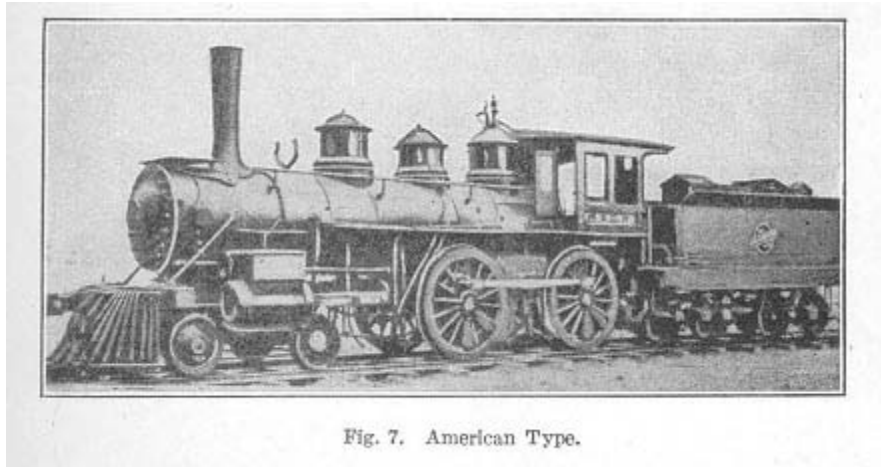

Fig. 6. The Reuben Wells.

The Reuben Wells, illustrated in [Fig. 6](#), was designed by Mr. Reuben Wells, then a master mechanic of the road. It was built in the company's shops at Jeffersonville, Indiana, in July, 1858. The Reuben Wells has cylinders 20 X 24 inches, and five pairs of drivers each 49 inches in diameter, all being coupled. No front truck is used. The boiler is 56 inches in diameter and contains 201 two-inch flues 12 feet 2 inches in length. It has a heating surface in the fire-box of 116 square feet while that in the tubes is 1,262 square feet. It is what is commonly known as a *tank locomotive* since it carries the water and fuel upon the frame and wheels of the engine proper instead of upon a separate part, the tender. The total weight with fuel and water is 112,000 pounds. The tractive effort under a steam pressure of 100 pounds per square inch is about 21,818 pounds on a level road. After having been in service for a number of years, it was rebuilt with four instead of five pair of drivers and was shortened by the cutting off of a section at the rear which had

been used for coal and water. Sufficient water capacity was provided by placing a tank over the boiler.



The American type locomotive, illustrated in [Fig. 7](#), is typical of the small sized engines of this construction which are now being rapidly replaced by other types. For a period of nearly fifty years ending about 1895, the American type locomotive was more commonly used for passenger service than any other type.

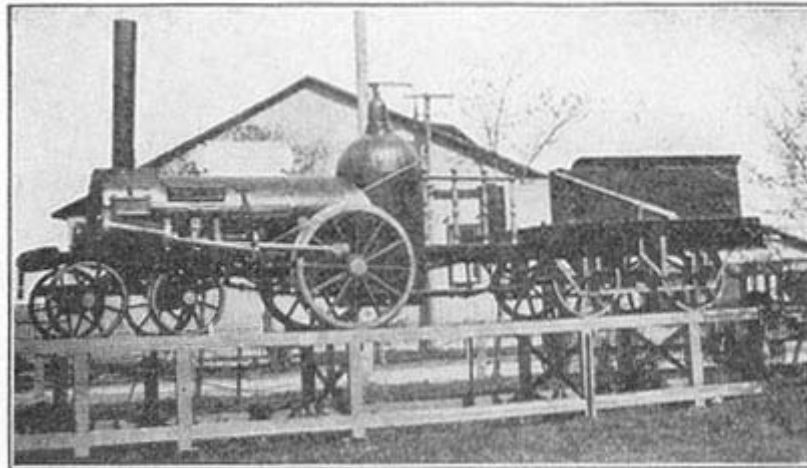

Fig. 8. The Tornado.

A comparison of things with reference to size, weight, and color impresses their relative characteristics upon the mind. For this reason, the illustrations of the *Tornado* and the *Mallet* compound locomotives are given in [Fig. 8](#) and [Fig. 9](#), respectively, the former being an early development, and the latter the most recent heavy freight locomotive.

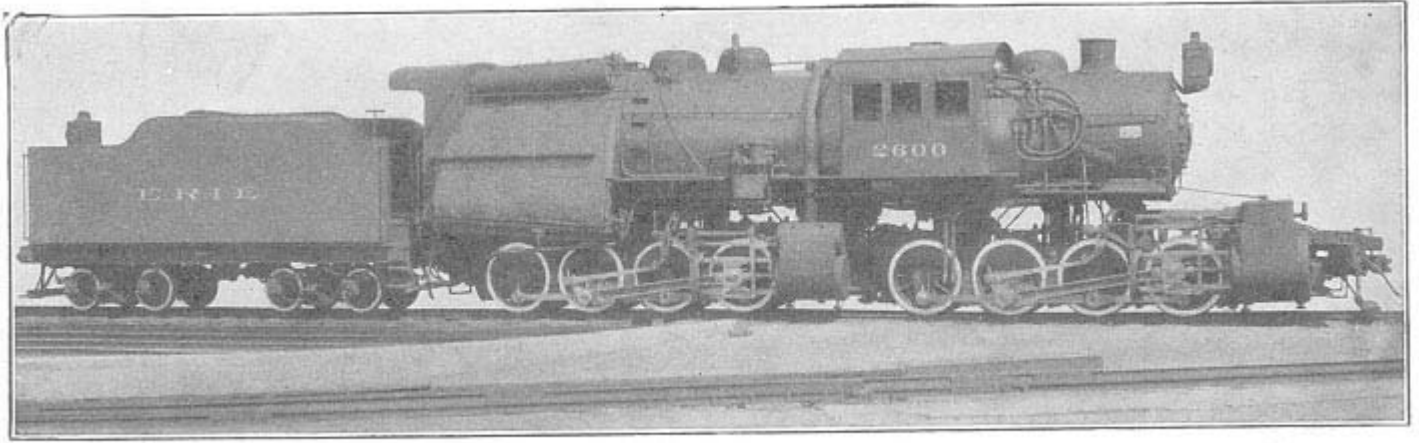

Fig. 9. Mallet Compound Locomotive.

The Tornado was the second locomotive owned by one of the parent lines forming a part of the Seaboard Air Line Railroad. This locomotive was imported from England and put into service in March, 1840. It has two inclined cylinders 9 inches in diameter with a common stroke of 20 inches and a single pair of drivers 54 inches in diameter. The fire-box stands upright and is cylindrical in form, while the boiler proper is horizontal and but 34 inches in diameter. The steam is admitted to an exhaust from the cylinders by plain slide valves controlled by the *Hook* motion.

The Mallet compound locomotive marks one of the most successful attempts of the locomotive designer and builder. It surpasses anything thus far built in size and combination of new ideas in design. The one shown in the illustration was built for the Erie Railroad for heavy pushing service. It has a boiler diameter of 84 inches and carries a steam pressure of 215 pounds per square inch. The boiler contains 404 two and one-fourth inch flues 21 feet long. Its high-pressure and low-pressure cylinders are 25 and 39 inches in diameter, respectively, having a common stroke of 28 inches. The drivers, sixteen in number, are each 64 inches in diameter. The total weight on the drivers is 410,000 pounds. The boiler has a total heating surface of 5313.7 square feet, 4971.5 of this number being in the tubes and 342.2 in the fire-box. The firebox is 126 inches long and 114 inches wide, giving 100 square feet of grate area. Its maximum tractive effort is 94,800 pounds.

It is of much interest to compare in a general way the developments of the locomotive in England and in America. The types differ in many respects, as shown in Table 1.

**TABLE I**

**\*Comparison of English and American Locomotives**

<b>Parts</b>	<b>English</b>	<b>American</b>
Frames	Plate	Bar
Cylinders	Inside	Outside
Drivers	Not equalized	Equalized
Driver Centers	Wrought iron	Cast iron or steel
Fire-box	Copper	Steel
Tubes	Brass	Iron
Cab	Small	Large
Pilot	No	Yes
Reverse gear	Screw	Lever
Boiler	Small and Low	Large and high

\* The comparisons are not strictly true for every case but represent the conditions usually found.

In order that a clear understanding may be had of the various types of locomotives, a classification is given according to wheel arrangement. In the Whyte system of classification, which is quite largely used, each set of trucks and driving wheels is grouped by number beginning at the pilot or front end of the engine. Thus, 260 means a Mogul, and 460, a 10-wheel engine. The first figure, 2, in 260 denotes that a 2-wheeled truck is used in front; the figure 6, that there are six coupled drivers, three on each side; and the 0, that no trailing truck is used. This scheme gives both a convenient and easy method of classifying locomotives.

In Table II is given the classification of the locomotives used on American railroads.

The method may be further extended to include the weights of locomotives. The total weight is expressed in units of 1,000 pounds. Thus: A Pacific locomotive weighing 189,000 pounds would be classified as Type 462-189. If the locomotive is a compound, a letter C would be used instead of the dash. Thus: Type 462-C-189. If tanks are used instead of a separate tender, the letter T would be substituted for the dash. Thus: A tank locomotive having four driving wheels, a 4-wheel leading truck, and a 4-wheel rear truck, weighing 114,000 pounds would be classified as Type 444-T-114.



**TABLE II**  
**Classification of Locomotives**  
**[WHYTE'S SYSTEM]**

040		4 Wheel
060		6 Wheel
080		8 Wheel
0440		Articulated
0660		Articulated
240		4 Coupled
260		Mogul
280		Consolidation
2440		Articulated
2100		Decapod
440		8 Wheel
460		10 "
480		12 "
042		4 Coupled and Trailing
062		6 " " "
082		8 " " "
044		Forney 4 Coupled
064		" 6 "
046		" 4 "
066		" 6 "
242		Columbia
262		Prairie
282		8 Coupled
2102		10 "
244		4 "
264		6 "
284		8 "
246		4 "
266		6 "
442		Atlantic
462		Pacific
444		4 Coupled Double Ender
464		6 " " "
446		4 " " "

From the classification table given, it is apparent that there are a great many different types of locomotives in service. Only the more commonly used types will be discussed, which are as follows: 040, 060, 080, 260, 280, 440, 442, 460, and 462. The types 040, 060, and 080 are largely used for switching service. The 040 type is of the smallest proportions and weights, being found in small yards where only light work is required. The call for heavy duty was met by the 060 type. The fact that the 060 type, being much heavier, has a greater tractive effort and a correspondingly larger steaming capacity, has caused them to be used very extensively. The following figures will aid in giving an idea of their size and capacity:

Weight on drivers (pounds). ....	145,000 to 170,000
Diameter of cylinders (inches). ....	19 to 22
Stroke of piston (inches). ....	24 to 26
Diameter of driving wheels (inches). ....	50 to 56
Working steam pressure (pounds per square inch).....	180 to 200

The demand for power, steadily increasing beyond that which could be secured by locomotives of the 060 type, created a new design known as the 8-wheel, or 080 type. This type is used in switching and pushing service and has about 171,000 pounds weight on drivers, cylinders 21 inches in diameter, stroke 28 inches, drivers 51 inches in diameter, and carries 175 to 200 pounds steam pressure. The switching engines of the 060 and 080 type were converted into highclass freight engines by adding two wheel trucks to each, thus developing the 260, or Mogul, and the 280, or Consolidation types.

The Mogul was primarily intended for freight service only, but it is sometimes used in heavy passenger service. The object of the design was to obtain greater tractive force on driving wheels than is possible to obtain with four drivers, as in the 440 type. [Fig. 10](#) illustrates a modern 260, or Mogul type, giving its principal dimensions. This type was more generally used than any other before the increasing requirements of heavy freight service resulted in the development of the 280, or Consolidation type. It is profitable from the standpoint of economy in repairs in selecting the type of locomotive for any service, to use the minimum number of drive wheels possible within the limits of the necessary tractive power, although for freight service involving the handling of heavy trains on steep grades, the 280, or Consolidation type, is required. Where the requirements are not too severe, however, there is a large field for the Mogul type in freight service. Where a large axle load is permitted, the Mogul type may give sufficient hauling capacity to meet ordinary requirements in freight service on comparatively level roads. While not generally recommended for what may be called fast freight service, the 280, or Consolidation type, is sometimes used. Many Mogul locomotives are successfully handling such trains.

The 260 type provides a two-wheel leading truck with good guiding qualities and places a large percentage of the total weight on the driving wheels. A large number of locomotives of this type show an average of 87½ per cent of the total weight of the locomotive on the drivers. Boilers with sufficient capacity for moderate speed may be provided in this type; and with relatively small diameters of driving wheels, it will lend itself readily to wide variations in grates and fireboxes.

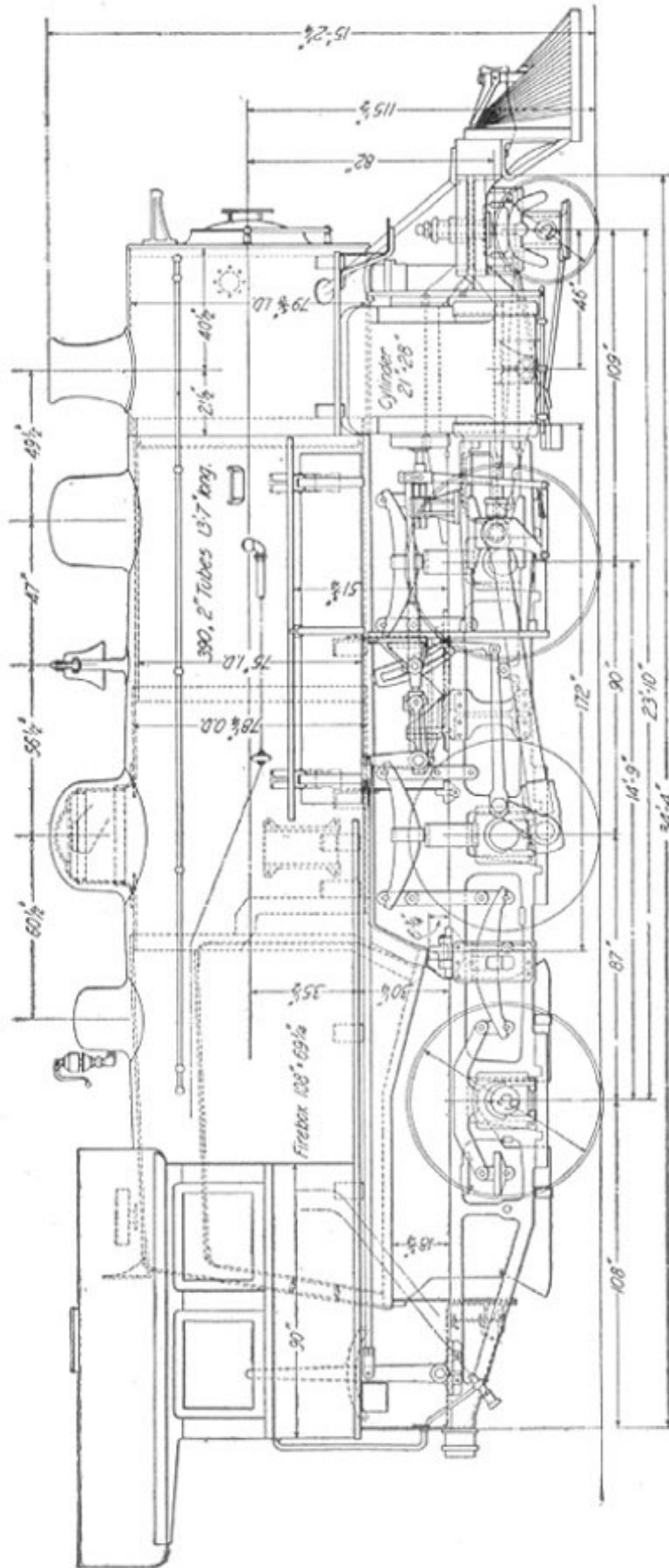

Fig 10. Modern 260, or Mogul Type of Locomotive.



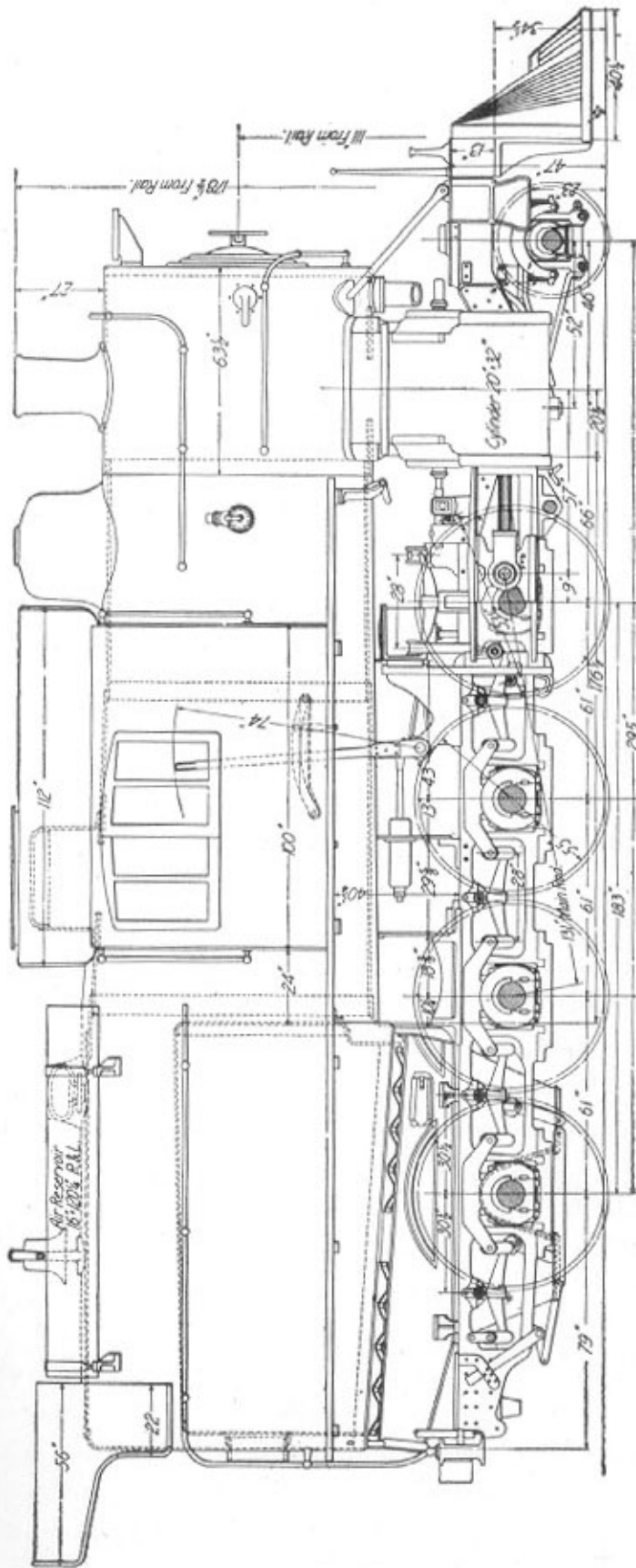

Fig. 11. A 280, or Consolidation Type of Locomotive.

The Consolidation locomotive, or 280 type, shown in [Fig. 11](#), was designed, as has been mentioned, for hauling heavy trains over steep grades. It is perhaps more generally used as a high class freight engine than any other type so far developed. Locomotives of this type have been designed and built with total weights varying between 150,000 to 300,000 pounds.

The four most prominent types of passenger locomotives, namely, 440, 442, 460, and 462, have each been developed at different times and in successive order to meet the ever-increasing and changing demands. The 8-wheel or 440 type, commonly known as the *American type*, was for some time the favorite passenger locomotive, but as the demands for meeting the conditions of modern fast passenger service increased, a locomotive of new design was required. The conditions which were to be met were *sustained high speed* and *regular service*. This did not mean bursts of high speed under favorable conditions with a light train running as an extra or special with clear orders, but it meant rather the more exacting requirements of regular service.

Where regular train service had to be sustained day after day at a schedule of 50 miles per hour, it required reserve power to meet the unfavorable conditions of the weather and for an occasional extra car in the train. For such exacting demands, much steam is required and ample heating and grate surface must be provided. In the 440 type with a 4-wheel leading truck and four driving wheels without a trailing truck, the boiler capacity is limited. Not only is the heating surface also limited but the grate area as well, because the grates must be placed between the driving wheels. The desirability of larger boilers and wider grates than the distance between the wheels in the 440 type will permit, led to a ready acceptance of the 442, or Atlantic type locomotive, as shown in [Fig. 12](#). The 442 type combines a 4-wheel leading truck, providing good guiding qualities, and four coupled driving wheels having a starting capacity sufficient for trains of moderate weight, and a trailing truck. The use of the trailing truck permits the extension of the grates beyond the driving wheels thus obtaining a much larger grate area. This wheel arrangement also permits the use of a deep as well as a wide fire-box which is especially advantageous in the burning of bituminous coal. It also gives a much greater depth at the front or throat of the fire-box, which is very important.

As modern passenger service increased and heavier trains had to be drawn, four driving wheels would not give sufficient starting power. Because of the heating surface and grate area being limited by the same factors as mentioned in the 440 type, another type, the 462, or Pacific type, came into favor. As this type was called upon to pull the heaviest passenger trains, much power was required even under very favorable conditions. For such trains, a locomotive having a combination of large cylinders, heavy tractive weight, and large boiler capacity is required. The Pacific type meets these requirements in a very successful way. From a study of [Fig. 13](#), which illustrates such a locomotive, it is obvious that the 462 type differs from the general design of the Atlantic type only in the addition of another pair of driving wheels. This, however, makes possible a much heavier boiler; therefore, more heating surface, more grate area, and greater tractive weight are obtained. Grate areas of from 40 to 50 square feet are possible in this type which provides for the large fuel consumption that is required for the rather severe service. The heating surface is of equal importance since large cylinders require large steaming capacity. The 462 type meets this need also. A comparison of passenger locomotives shows that the Pacific type has more heating surface for a given total weight than is found in any other type of passenger locomotive.

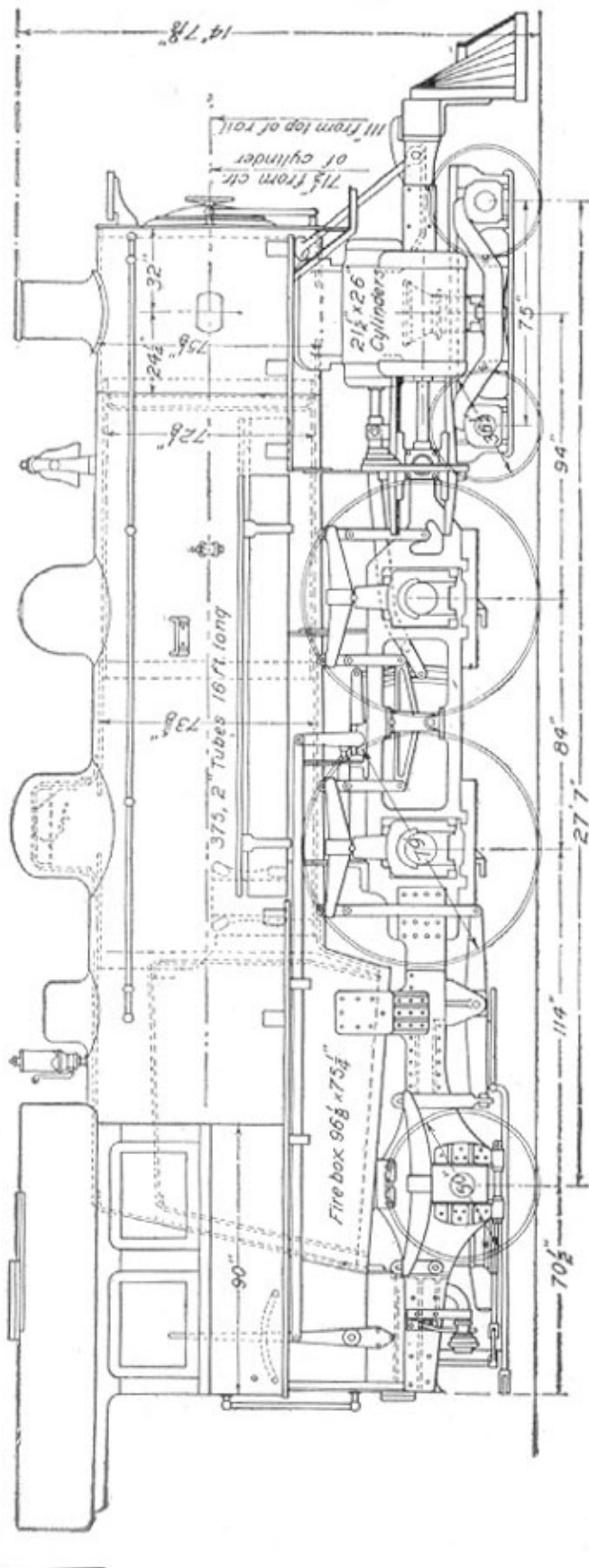

Fig. 12. A 442, or Atlantic Type of Locomotive.

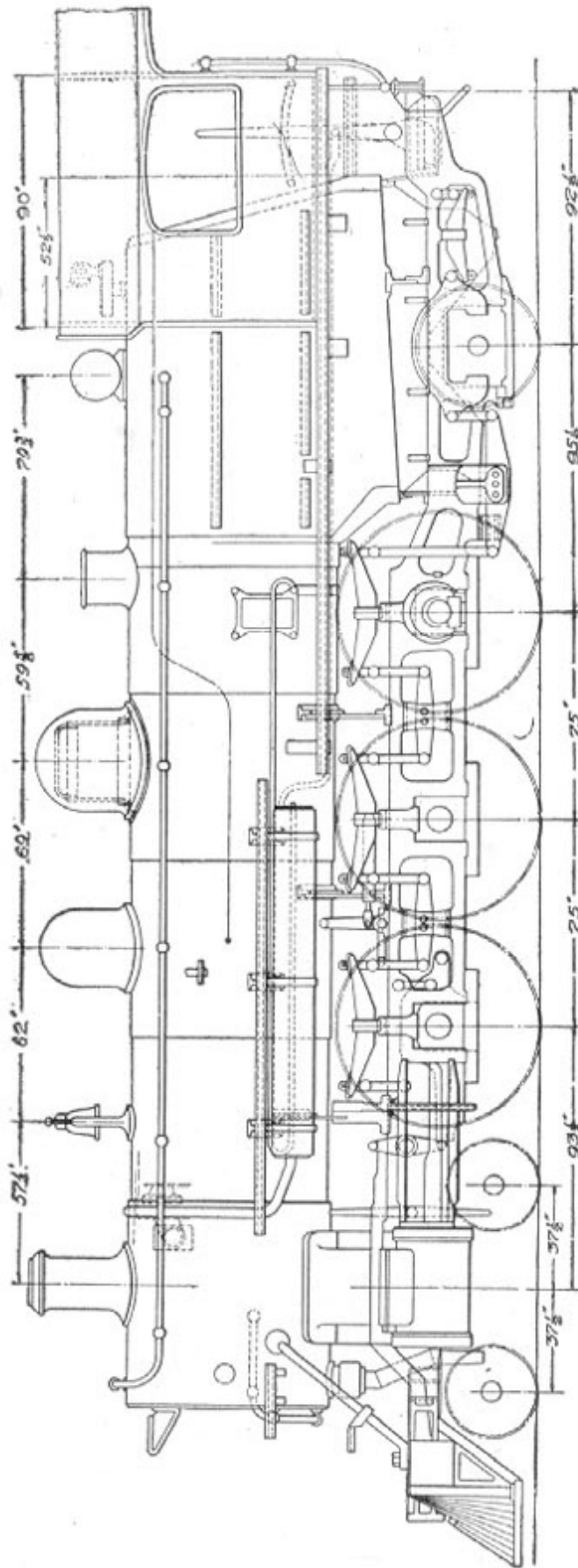

Fig. 13. A 462, or Pacific Type of Locomotive for Very Heavy Passenger Service.

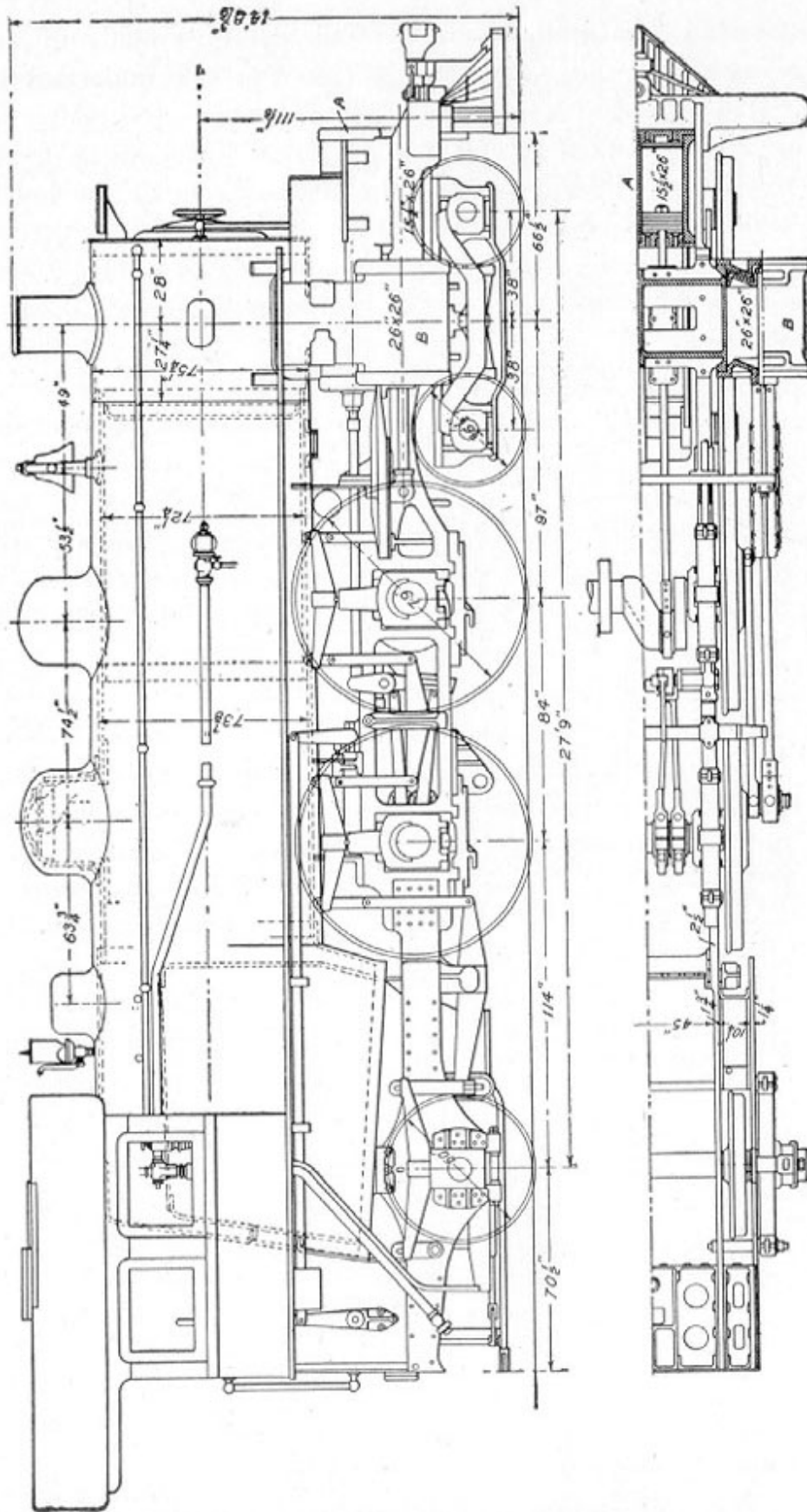

Fig. 14. Elevation of a Cote Four-Cylinder Balanced Compound Locomotive.  
 Fig. 15. Plan of the Same Locomotive.

**Compound Locomotive.** In continuation of a study of the development of the various types of locomotives, it is important to consider the compound locomotive. The compound locomotive is one in which the steam is admitted to one cylinder, called the *high-pressure cylinder*, where it partially expands. From this cylinder the steam is exhausted into the steam chest of another cylinder having larger dimensions, called the *low-pressure cylinder*. From this steam chest, the steam enters the low-pressure cylinder where it continues its work and is exhausted into the atmosphere. There have been a large number of different types of compound locomotives developed, all of which have had more or less merit. The following types have been used in America: the four-cylinder balance compound, the Mallet compound, and the tandem compound. The remarks and description which follow, of the *Cole four-cylinder compound*, are quoted from publications of the American Locomotive Company, builders of this locomotive:

The time has arrived when merely increasing weight and size of locomotives to meet increasing weights of trains and severity of service does not suffice. To increase capacity, improve economy, and at the same time reduce injury to track, a new development is needed. Limits of size and weights have been reached in Europe and to meet analogous conditions there, the four-cylinder balanced compound has been developed into remarkably successful practice. The purpose of the Cole four-cylinder balanced compound is to advance American practice by adapting to our conditions the principles which have brought such advantageous results abroad, especially the principles of the de Glehn compound.

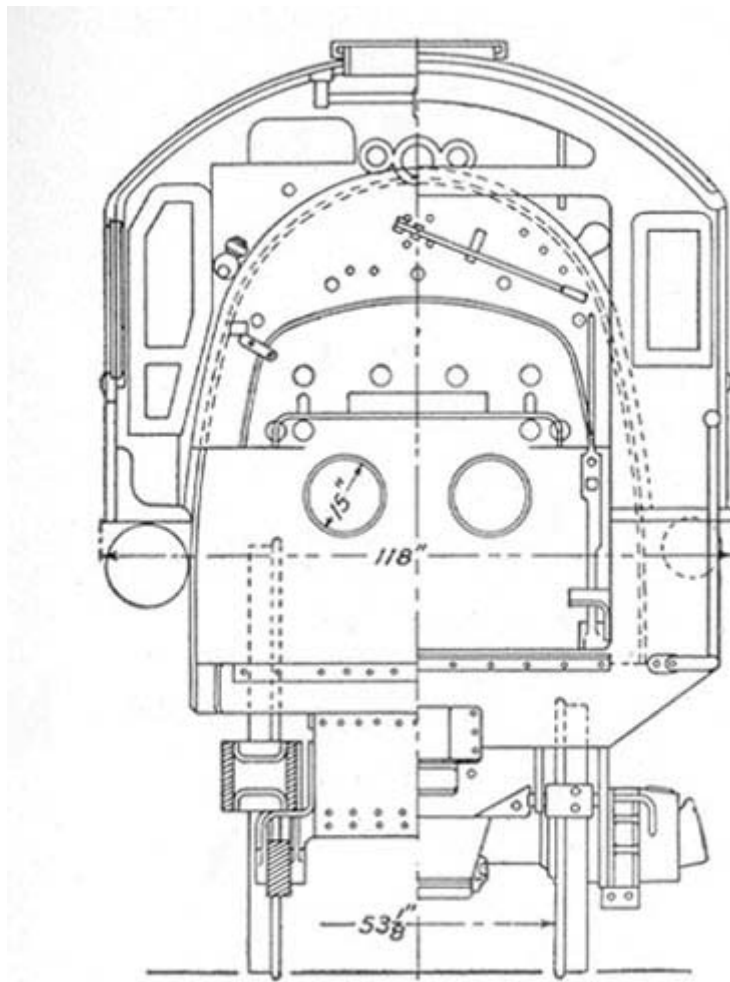

Fig. 16. Rear Elevation of the Cole Compound.

The Cole four-cylinder balanced compound employs the principle of subdivided power to the cylinders; the high pressure (between the frames) drives the forward or crank axle and the others; the low pressure (outside of the frames) drives the second driving axle. In order to secure a good length for connecting rods without lengthening the boiler, the high-pressure cylinders are located in advance of their usual position.

Special stress is laid on perfect balancing and the elimination of the usual unbalanced vertical component of the counterbalance stresses as a means for increasing the capacity, improving economy of operation and maintenance, and promoting good conditions of the track.

The relative positions of the high-pressure cylinder *A* and the low-pressure cylinder *B* may be seen in [Fig. 14](#) and [Fig. 15](#). The high-pressure guides, [Fig. 15](#), are located under and attach to the low-pressure saddle, whereas the low-pressure guides are in the usual location outside of the frames. The cranks of the driving wheels are 180 degrees apart. In order to equalize the weights of the pistons, those of the high-pressure cylinders are solid and those of the low-pressure cylinders are dished, and made as light as possible. A single valve motion, of the Stephenson type, operates a single valve stem on each side of the engine. Each valve stem carries two piston valves, one for the high- and the other for the low-pressure cylinder, as illustrated and explained later.

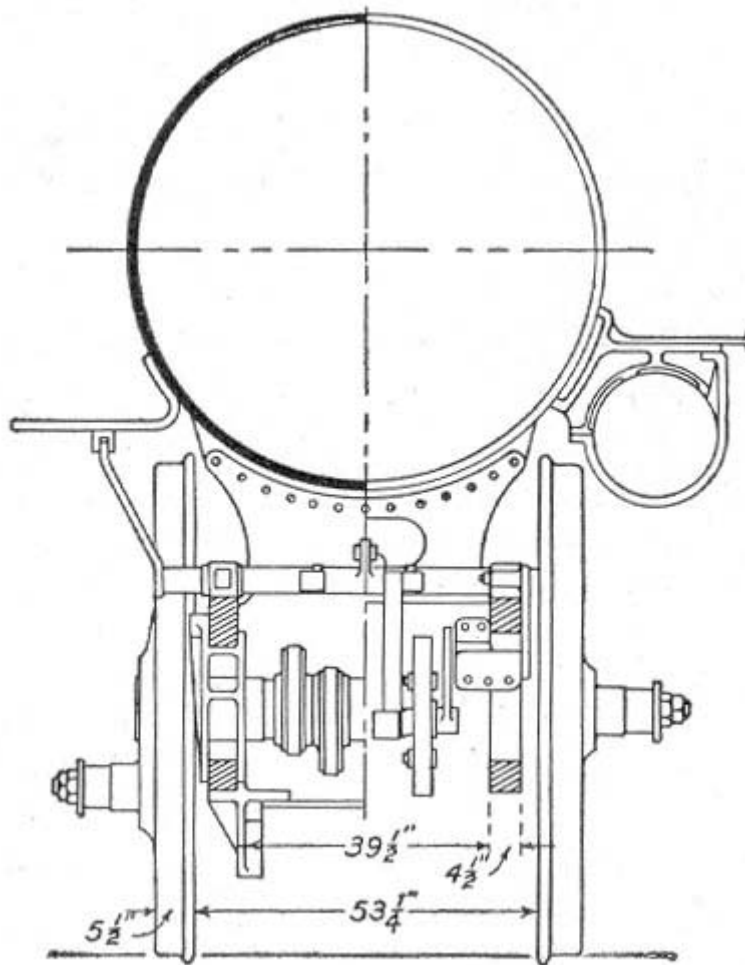

Fig. 17. Section of the Cole Compound.

The back end, [Fig. 16](#), and the two sections, [Fig. 17](#) and [Fig. 18](#), resemble ordinary construction of two-cylinder locomotives but the half front elevation and half section shown in [Fig. 19](#) disclose a number of departures. The high-pressure piston rod, crosshead, and the guides *C* are shown in position under the low-pressure saddle. The high-pressure cylinders *A* and the high-pressure section of the piston valve chamber *D* are all in one casting, [Fig. 20](#). The sides of the cylinder casting are faced off to the exact distance between the front plate extension of the frames. The valve chambers are in exact line with the valve chambers of the



low-pressure cylinder; intermediate thimble castings and packing glands being inserted between the two, form a continuous valve chamber common to both high- and low-pressure cylinders, thus providing for expansion.

*Fig. 21* shows the low-pressure cylinders *B* which are cast separately and bolted together. In this case the inside of the cylinders are faced off to proper dimensions to embrace the outer faces of the bar frame. The low-pressure piston valve chamber *F* is in direct line between the cylinder and the exhaust base *G*. This view illustrates the short direct exhaust passage *H* from the low-pressure cylinders to the exhaust nozzle.

*Fig. 22*, the crank axle, shows that under the existing conditions it is possible to make this part exceedingly strong. Inasmuch as the cranks on this axle are 90 degrees from one another, it is possible to introduce exceedingly strong 10 by 12½ inch rectangular sections connecting the two crank pins. The whole forms an exceedingly strong and durable arrangement constructed in accordance with the best European practice which is likely both to wear and stand up well in service. A cross-section of the central portion of the axle indicates its proportions between the crank pins.

The high- and low-pressure cylinders, *A* and *B*, are shown in *Fig. 23* as they would appear in section revolved into the same plane. The high-pressure valve *D* is arranged for central admission and the low-pressure valve *F* for central exhaust, both valves being hollow. A thimble casting or round joint ring and a gland connect the two parts of the continuous valve chamber *I*.

The following advantages of the four-cylinder balanced compound are claimed by the maker:

1. The approximately perfect balance of the reciprocating parts combined with the perfect balance of the revolving masses.
2. The permissible increase of weight on the driving wheels on account of the complete elimination of the hammer blow.
3. An increase in sustained horse-power at high speeds without modification of the boiler.
4. Economy of fuel and water.
5. The subdivision of power between the four cylinders and between the two axles, and the reduction of bending stress on the crank axle due to piston thrust because of this division of power.
6. The advantage of light moving parts which render them easily handled and which will minimize wear and repairs.
7. Simplicity of design One set of valve gears with comparatively few parts when compared with other designs which have duplicate sets of valve gears for similar locomotives.



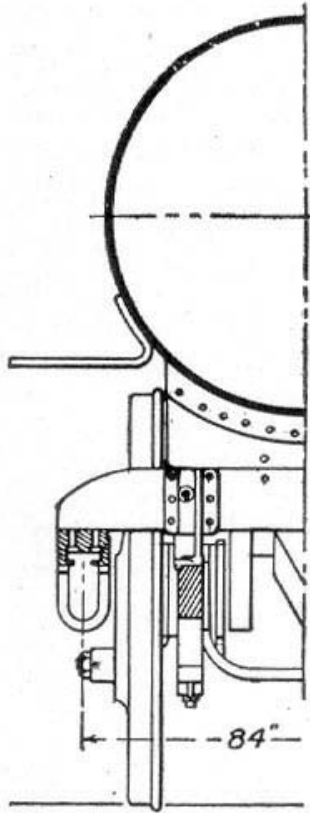

Fig. 18. Half-Section of the Cole Compound.

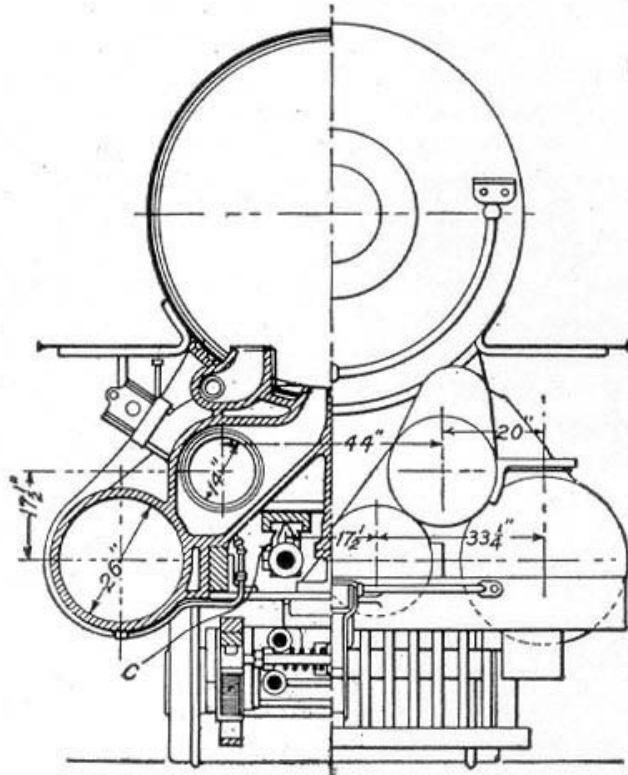

Fig. 19. Half Front Elevation and Half-Section.

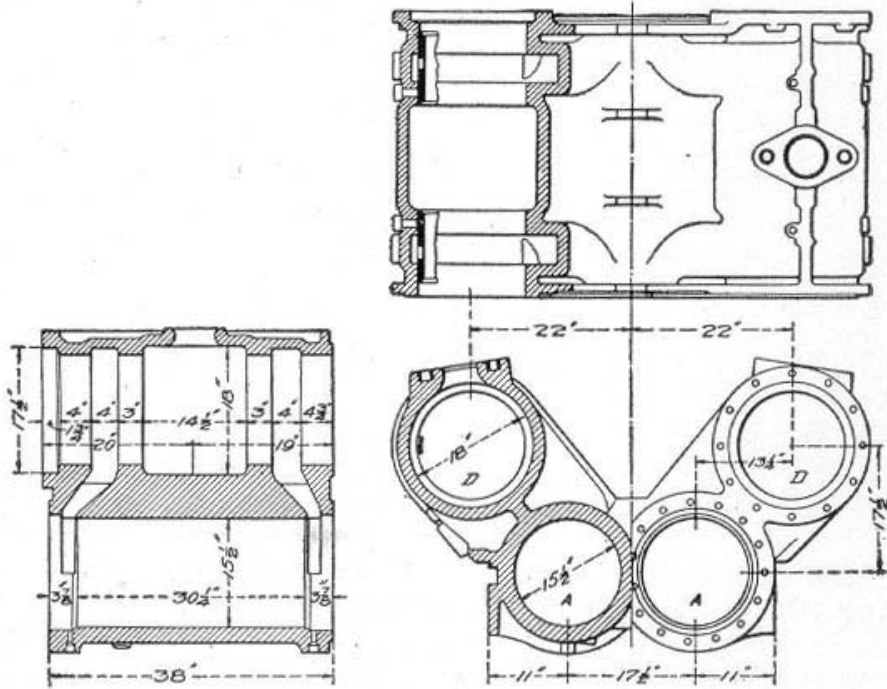

Fig. 20. Details of the Cylinders in the Cole Compound.



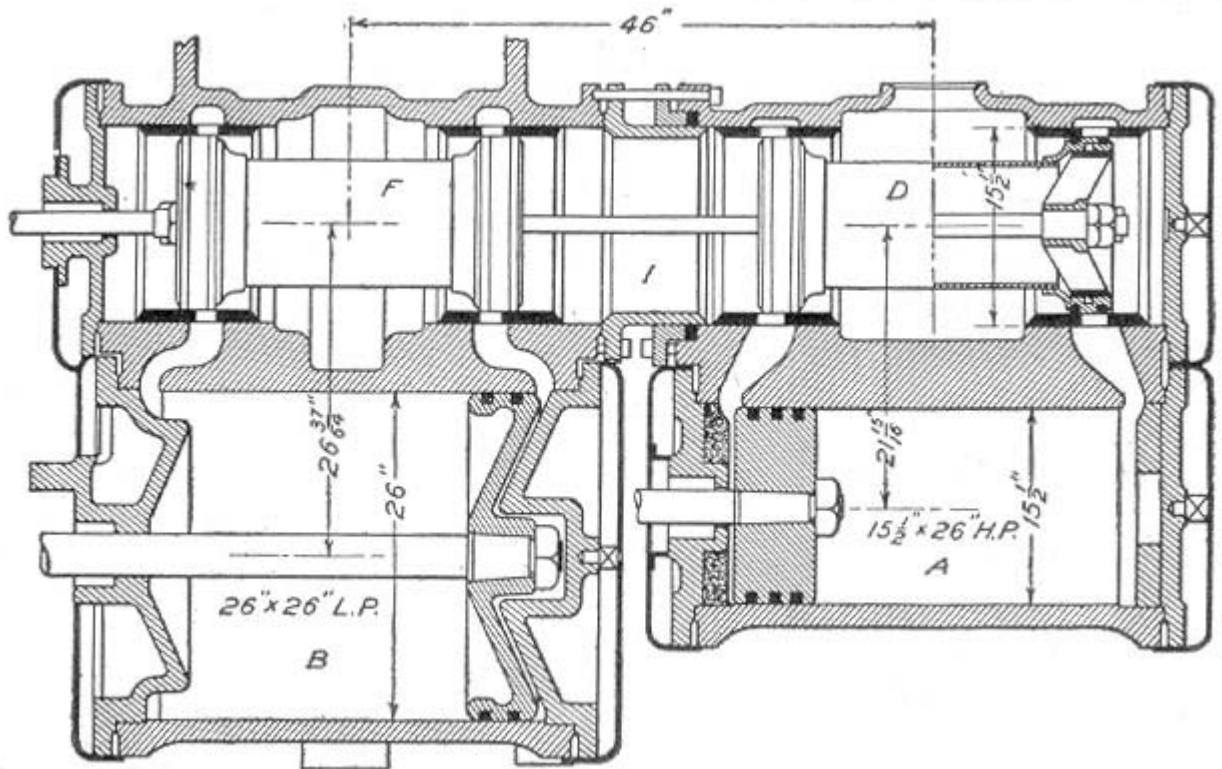

Fig. 23. Section of High- and Low-Pressure Cylinders Revolved into the Same Plane.

Another type of compound which is remarkable in many respects and which has had very successful usage in Europe is the *Mallet articulated compound*. It has been known and used in certain mountainous sections of Europe for several years but has recently been modified and adapted to meet American requirements. It is practically two separate locomotives combined in one, and advantage is taken of this opportunity to introduce the compound principles under the most favorable conditions. The following is a description together with dimensions of a large locomotive of this type built by the American Locomotive Company. Its enormous size is realized from [Fig. 24](#) and [Fig. 25](#). The weight of this particular locomotive in working order is nearly 335,000 pounds and the flues are 21 feet long. The rear three pairs of drivers are carried in frames rigidly attached to the boiler. To these frames, and to the boiler as well, are attached the high-pressure cylinders. The forward three pairs of drivers, however, are carried in frames which are not rigidly connected to the barrel of the boiler but which are in fact a truck. This truck swivels radially from a center pin located in advance of the high-pressure cylinder saddles. The weight of the forward end of the boiler is transmitted to the forward truck through the medium of side bearings, illustrated in [Fig. 24](#), between the second and third pair of drivers. In order to secure the proper distribution of weight, the back ends of the front frames are connected by vertical bolts with the front ends of the rear frames. These bolts are so arranged that they have a universal motion, top and bottom, which permits of a certain amount of play between the front and rear frames when the locomotive is rounding a curve. The low-pressure cylinders are attached to the forward truck frames.

The steam dome is placed directly over the high-pressure cylinders *A* from which steam is conducted down the outside of the boiler on either side to the high-pressure valve chamber. The steam after being used in the high-pressure cylinders *A* passes to a jointed

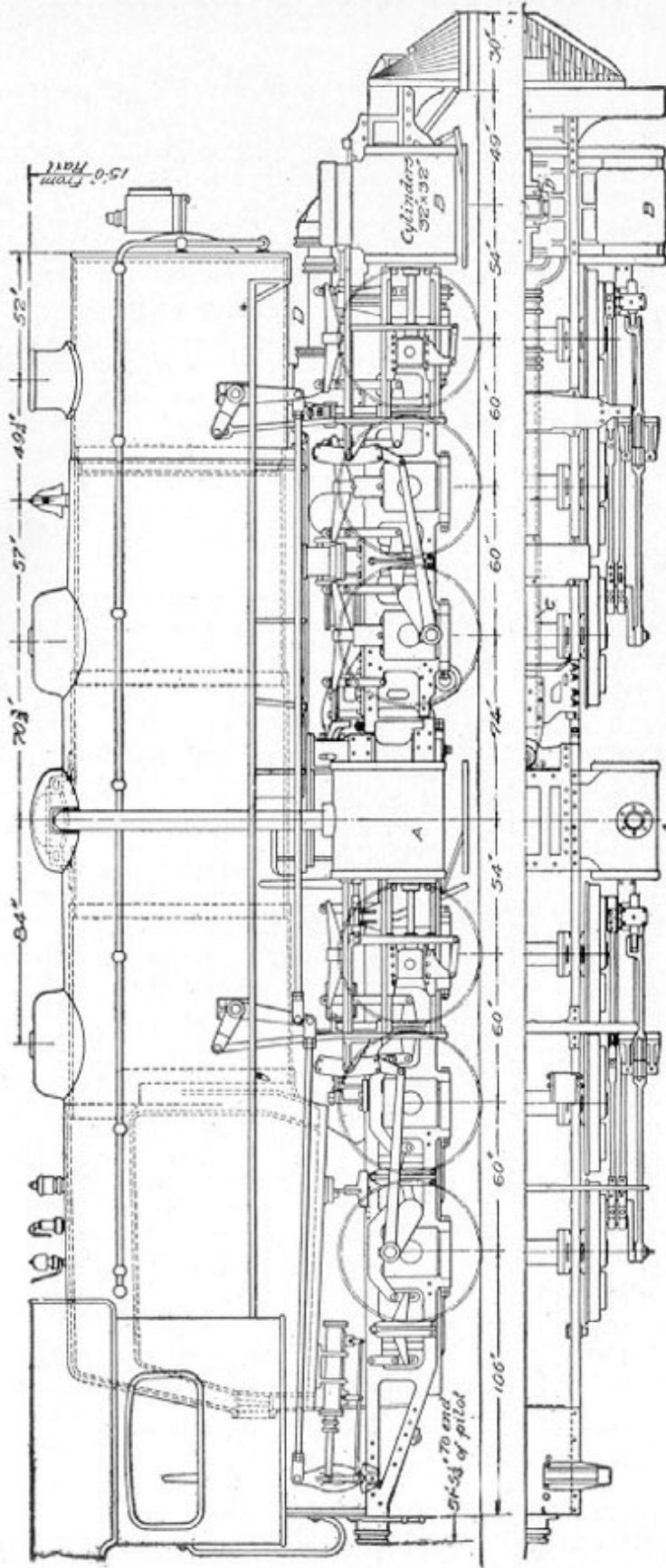
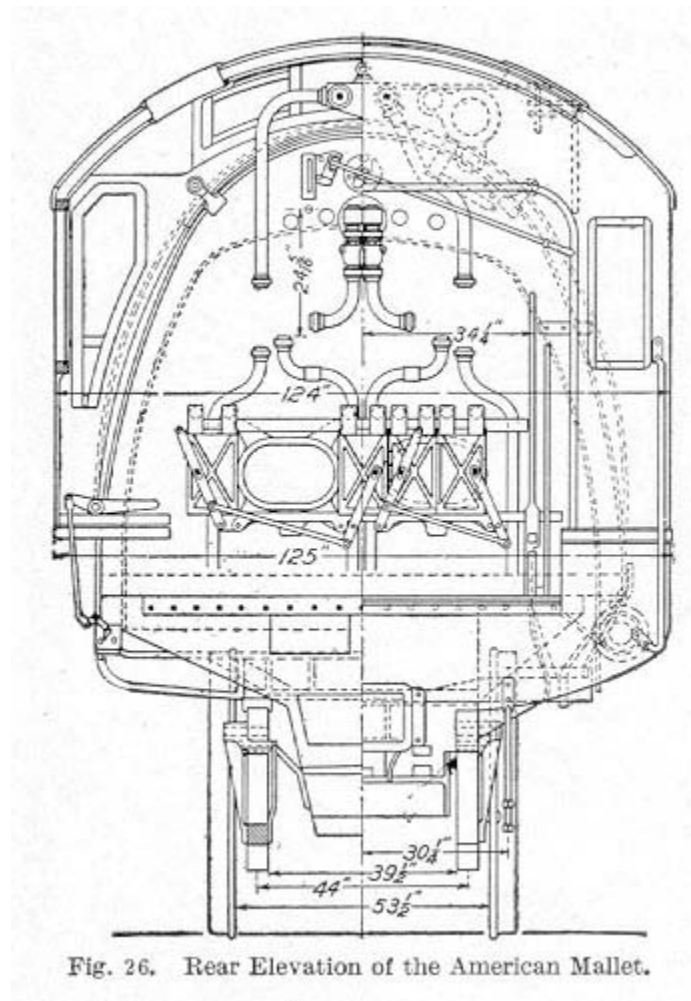

Fig. 24. Elevation of American Model of Mallet Articulated Compound.

Fig. 25. Half-Plan of the Same.

pipe *C* between the frames and is delivered to the low-pressure cylinders *B*, whence it is exhausted by a jointed pipe *D* through the stack in the usual way. The back end, [Fig. 26](#), presents no unusual feature other than the great size of the boiler and fire-box. The section shown in [Fig. 27](#) illustrates the method of bringing the steam down from the steam dome to the high-pressure valve *E*. The section in [Fig. 28](#) clearly shows the sliding



support *F* between the boiler and front truck. It also shows the method of attaching the lift shafts to the boiler barrel which is made necessary by the use of the Walschaert valve gear. [Fig. 29](#) shows that the low-pressure cylinders *B* are fitted with slide valves, and also shows the jointed exhaust pipe from the low-pressure cylinder to the bottom of the smoke-box. [Fig. 30](#) illustrates the construction and arrangement of the flexible pipe connection *C* between the high-pressure cylinder *A* and the low-pressure cylinder *B*. This pipe connection, as well as the exhaust connection *D* between the low-pressure cylinder and the smoke stack, serves as a receiver. The ball joints are ground in, the construction being such that the gland may be tightened without gripping the ball joint.

The builders claim for this design about the same advantages over the simple engine as were enumerated in the description of the Cole four-cylinder balanced compound. It is evident that the Mallet compound is a large unit and hence can deliver more power with the same effort of the crew. A reserve power of about 20 per cent above the normal capacity of the locomotive may be obtained by turning live steam into all four cylinders



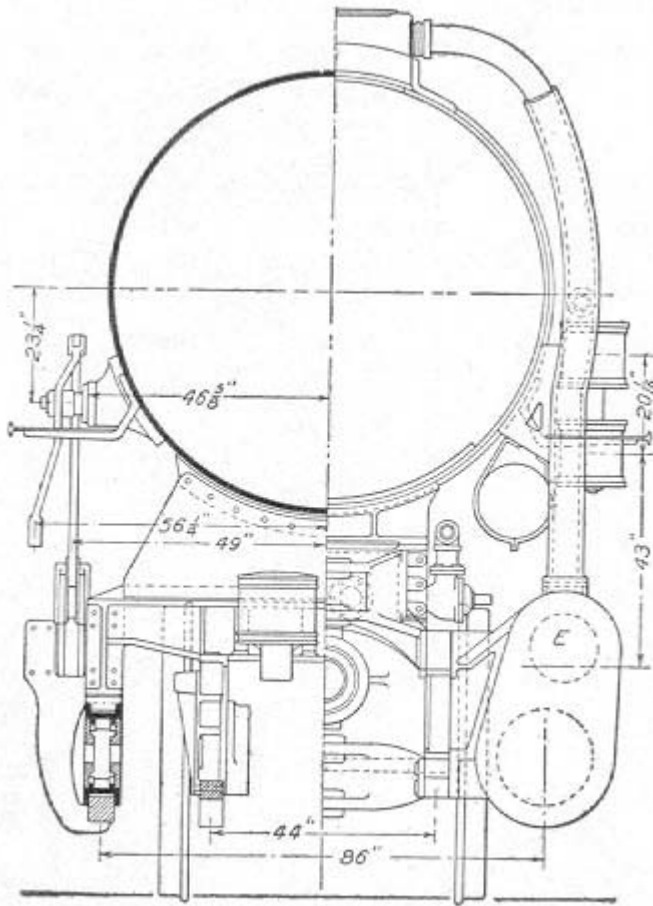

Fig. 27. Section of American Mallet Showing Method of Bringing Steam from Dome to High-Pressure Cylinder.

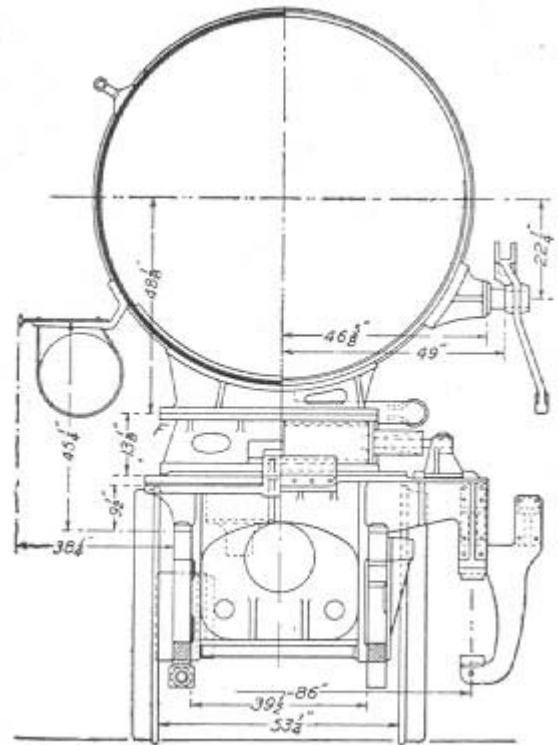

Fig. 28. Section of American Mallet.

and running the locomotive simple which can be done at the will of the engineer when circumstances demand it.

The diagrammatic illustration shown in [Fig. 31](#) presents a good means of studying and comparing the four different types of compound locomotives referred to in the preceding pages. Briefly stated, the essentials in each of the four cases illustrated are as follows:

*Cole.* High-pressure cylinders, inside but in advance of the smoke-box, driving front axle. Low-pressure cylinders, outside in line with the smoke-box, driving rear driving axle. Two piston valves on a single stem serve the steam distribution for each pair of cylinders, and each valve stem is worked from an ordinary link motion.

*Vauclain.* High-pressure cylinders inside and low-pressure cylinders outside, all on the same horizontal plane, in line with the smokebox and all driving the front driving axle. As in the von Borries, a single piston valve worked from a single link effects the steam distribution for the pair of cylinders on each side.

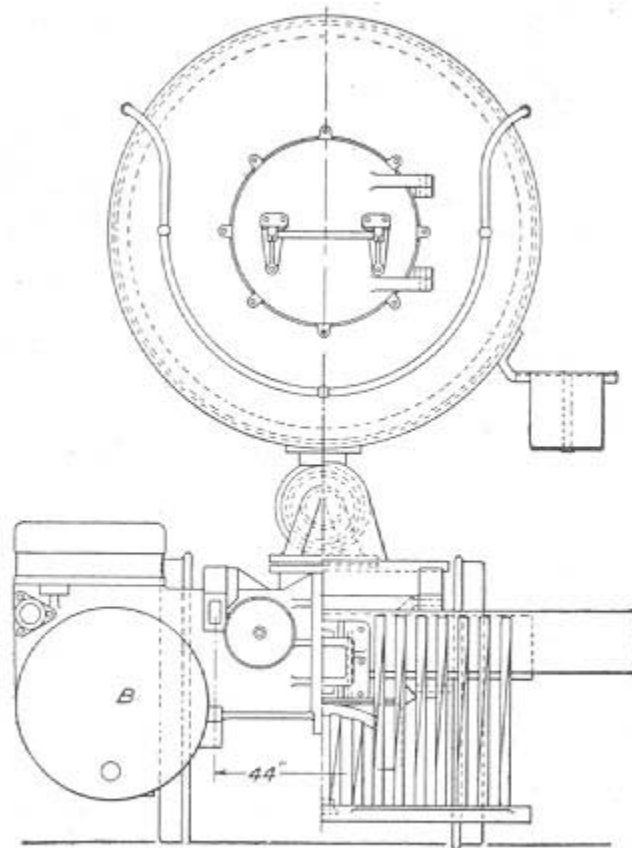

Fig. 29. Forward Half-Section Showing Slide Valves in the Low-Pressure Cylinders.

*De Glehn.* High-pressure cylinders, outside and behind smoke-box, driving the rear drivers. Low-pressure cylinders, inside under smoke-box, driving crank axle of front drivers. Four separate slide valves and four Walschaert valve gears allowing independent regulation of the high- and low-pressure valves.

*Von Borries.* High-pressure cylinders inside and low-pressure cylinders outside all on the same horizontal plane in line with the smoke-box and all driving the front driving axle. Each cylinder has its own valve but the two valves of each pair of cylinders are worked from a single valve motion of a modified Walschaert type. This arrangement permits the varying of the cut-off of the two cylinders giving different ratios of expansion which cannot, however, be varied by the engine-man.

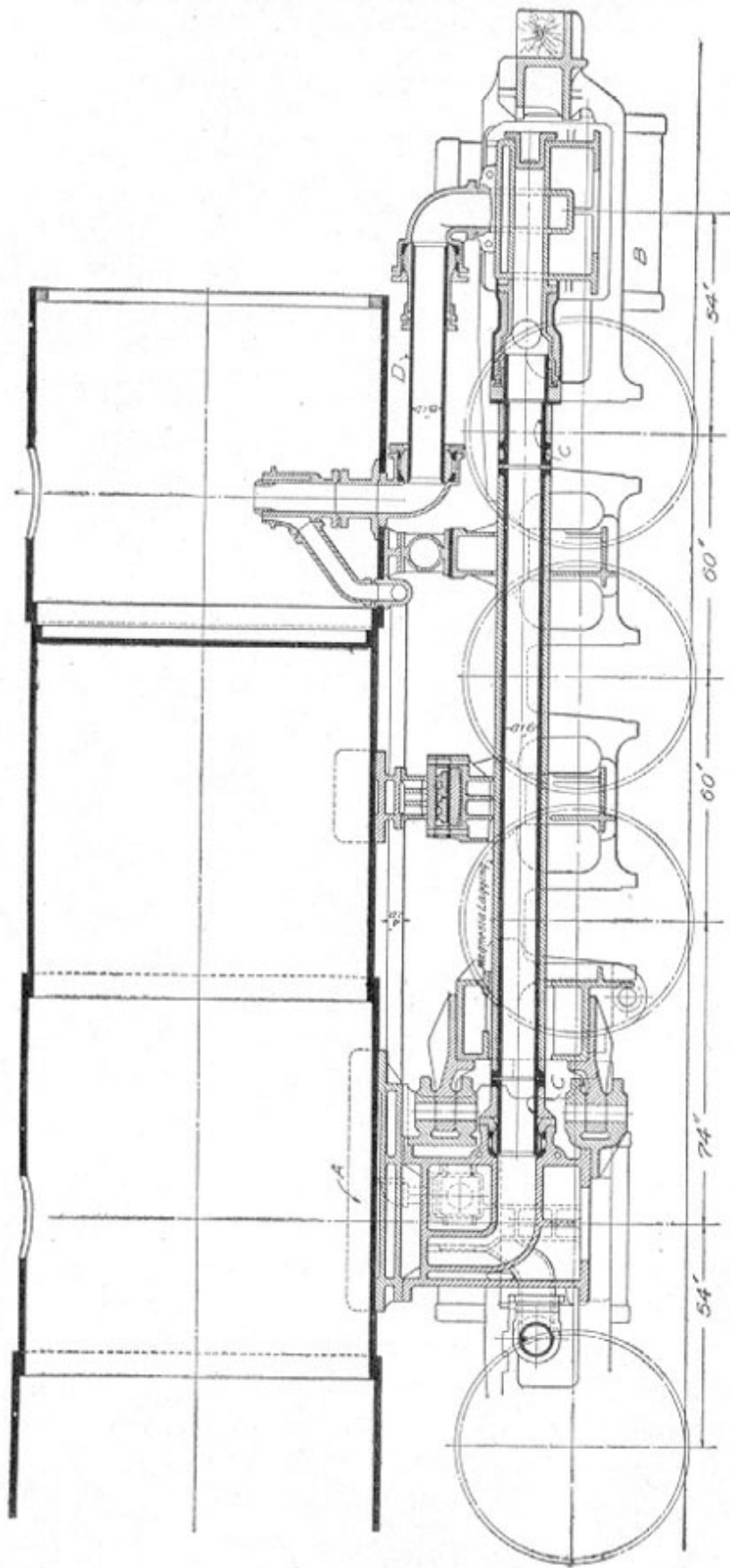

Fig. 30. Longitudinal Section of American Mallet Showing Flexible Pipe Connection Between High- and Low-Pressure Cylinders.



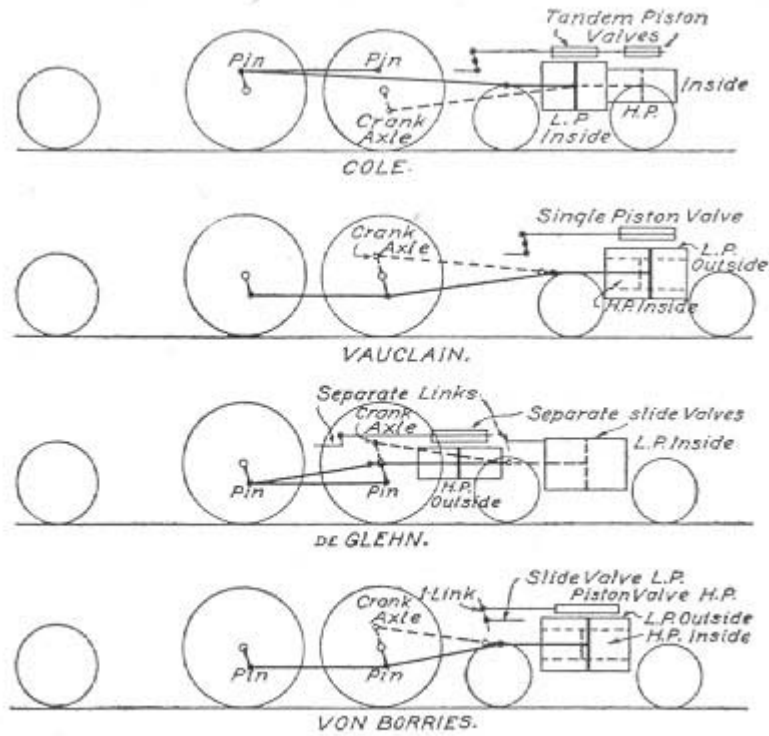

Fig. 31. Diagrams Showing Variations in the Four Principal Types of Compounds.

In addition to the compound locomotives already described, an early development of this type, known as the *Richmond*, or cross-compound, came into service. This engine differs from those already described in that it has only two cylinders, whereas those previously mentioned have four. In the cross-compound engine there is a high-pressure cylinder on the left side and a large or low-pressure cylinder on the right. The live steam passes from the boiler through the head and branch pipes to the high-pressure cylinder in the usual way. It is then exhausted into a receiver or circular pipe resembling the branch pipe which conveys the steam from the high-pressure cylinder across the inside of the smoke-box into the steam chest of the low-pressure cylinder. The steam passes from the steam chest into the cylinder and exhausts out through the stack in the usual way. The construction is such that the locomotive can be worked simple when starting trains. This type was never very largely used.

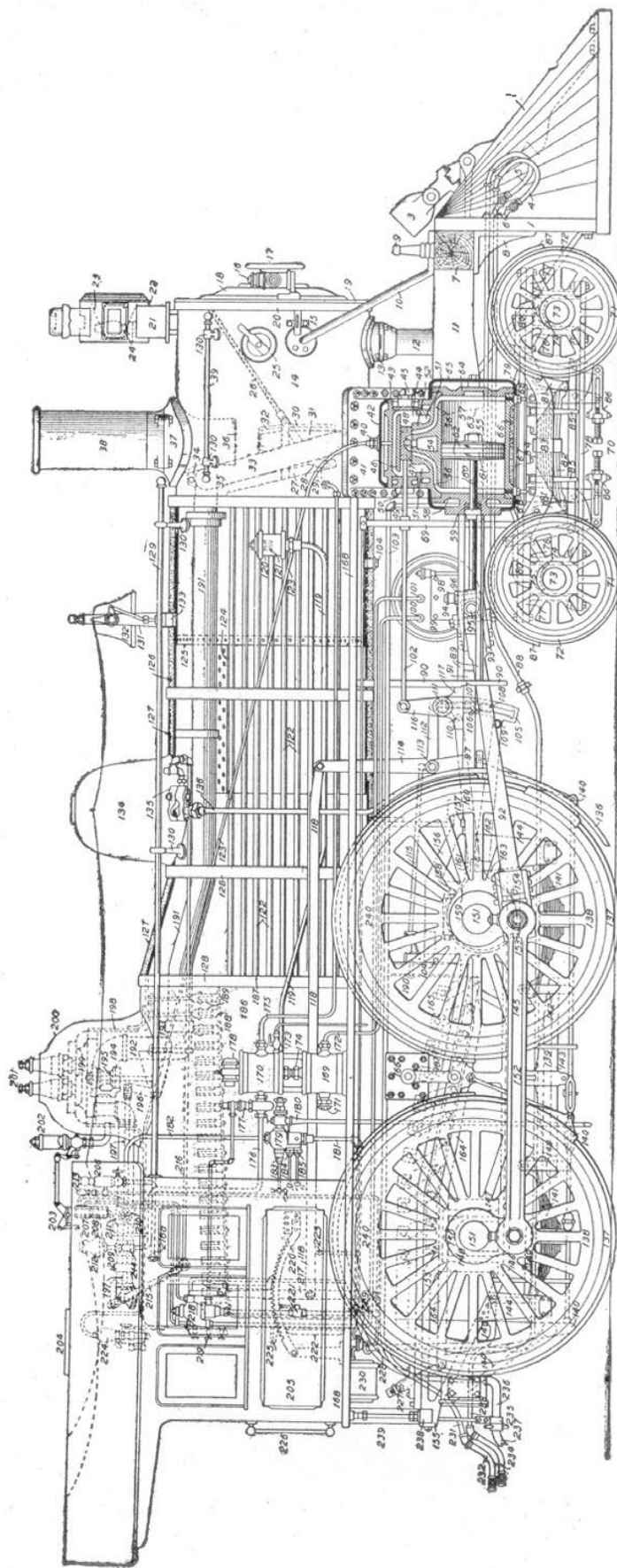

Fig. 32. Longitudinal Section of the American Locomotive.

Fig. 32. Longitudinal Section of the American Locomotive.

1-Pilot. 2-Draw Head Attachment. 3-Folding Draw Head. 4-Air Signal Hose. 5-Air Brake Hose. 6-Hose Hangers. 7-Buffer Beam. 8-Pilot Bracket. 9-Flagstaff. 10-Arch Brace. 11-Front Frame. 12-Cinder Chute. 13-Cinder Chute Slide. 14-Extension Front. 15-Headlight Front. 16-Signal Lamp. 17-Number Plate. 18-Smoke Arch Door. 19-Smoke Arch Front. 20-Smoke Arch Ring. 21-Headlight Bracket. 22-Headlight Case. 23-Headlight Reflector, 24-Headlight Burner. 25-Cleaning Door. 26-Netting. 27-Deflector Plate. 28-Deflector Plate Adjuster. 29-Air Pump Exhaust Pipe. 30-Blower. 31-Nozzle Stand. 32-Nozzle Tip. 33-Steam Pipe (2). 34-T or Nigger Head. 38-Dry Pipe Joint. 36-Petticoat or Draft Pipe. 37-Stack Base. 38-Smoke Stack. 39-Arch Hand Kail. 40-Oil Pipe Plug. 41-Cylinder Saddle. 42-Steam Chest Casing Cover. 43-Steam Chest Cover. 44-Steam Chest. 45-Relief Valve. 46-Balance Plate. 47-Balanced Valve. 48-Valve Yoke. 49-Valve Stem. 50-Valve Stem Packing. 51-Steam Passages to Chest. 52-Valve Seat. 53-Bridges. 54-Exhaust Port. 55-Piston Rod Nut. 56-Steam Ports. 57-Cylinder. 58-Back Cylinder Head. 69-Piston Rod Packing. 60-Piston Rod. 61-Piston Head. 62-Piston Packing Rings. 63-Truck Center Castings. 64-Front Cylinder Head. 65-Cylinder Head Casing. 66-Cylinder Lagging. 67-Cylinder Casing. 68-Cylinder Cocks. 69-Cylinder Cock Rigging. 70-Engine Track Wheel. 71-Engine Truck. 72-Engine Truck Tire. 73-Engine Truck Axle. 74-Engine Truck Brass. 75-Engine Truck Box. 76-Engine Truck Pedestal. 77-Engine Truck Frame. 78-Engine Truck Pedestal Brace. 79-Engine Truck Frame Brace. 80-Engine Truck Equalizer. 81-Engine Truck Spring Hanger. 82-Engine Truck Spring. 83-Engine Truck Spring Band. 84-Engine Truck Spring Pocket. 85-Safety Hanger. 86-Truck Brake. 87-Wheel Guard. 88-Signal Pipe. 89-Guides. 90-Guide Yoke. 91-Guide Block. 92-Main Rod, 93-Main Rod Front Strap. 94-Key. 95-Crosshead Pin. 95-Crosshead. 97-Main Frame. 98-Air Drum Bracket. 99-Air Drum. 100-Pump Connection. 101-Train Pipe Connection. 102-Valve Stem Rod. 103-Train Pipe. 104-Wash Out Plugs. 105-Link. 106-Suspension Stud. 107-Link Block Pin. 108-Link Block. 109-Eccentric Connection, Back Up. 110-Eccentric Connection, Go Ahead. 111-Link Hanger. 112-Tumbling Shaft Arm. 113-Tumbling Shaft. 114-Tumbling Shaft Lever. 115-Counterbalance Spring and Rig. 116-Rocker. 117-Rocker Box. 118-Reach Rod. 119-Branch Pipe. 120-Check Valve Case. 121-Check Valve. 122-Flues. 123-Oil Pipe. 124-Horizontal Boiler Seam. 125-Circumferential Seam. 126-Boiler Lagging. 127-Boiler Jacket. 128-Jacket Bands. 129-Hand Rail. 130-Hand Rail Brackets. 131-Bell Stand. 132-Bell. 133-Steam Bell Ringer. 134-Sand Box. 135-Pneumatic Sander. 136-Sand Pipe. 137-Driving Wheel Tire. 138-Driving Wheel Centers. 139-Ash Pan. 140-Driver Brakes. 141-Driver Springs. 142-Driver Spring Hangers. 143-Driver Spring Equalizers. 144-Driver Spring Hanger Brace. 145-Lower Rail of Frame. 146-Pedestal Brace. 147-Driving Box Shoe. 148-Driving Box Wedge. 149-Wedge Bolt. 150-Driving Box. 115-Driving Axle. 152-Side or Parallel Rod. 153-Rod Bush. 154-Main Rod Connection, 155-Main Frame. 156-Frame Brace. 157-Frame Splice. 158-Go Ahead Eccentric. 159-Back-Up Eccentric. 160-Go Ahead Eccentric Rod. 161-Go Ahead Eccentric Strap. 162-Back-Up Eccentric Rod. 163-Back-Up Eccentric Strap. 164-Grate Shaking Rig. 165-Rocking Grates. 166-expansion Pad. 167-Expansion Link. 168-Running Board. 169-Air Cylinder Brake Pump. 170-Steam Cylinder Brake Pump. 171-Air Strainer. 172-Delivery to Drum. 173-Drip Cock. 174-Pump Piston Packing. 175-Pump Exhaust Connection. 176-Pump Steam Connection. 177-Governor. 178-Pump Valve Case. 179-Injector. 180-Injector Overflow. 181-Water Pipe. 182-Steam Pipe. 183- Steam Valve. 184-Primer. 185-Water Valve. 186-Fire Box, 187-Tube Sheet. 188-Crown Bars. 189-Sling Stays. 190-Stay Bolts. 191-Dry Pipe. 192-Stand Pipe. 193-Dry Pipe Hangers. 194-Throttle Pipe. 195-Throttle Valve. 196-Throttle Bell Crank. 197-Throttle Stem. 198-Dome. 199-Dome Cap. 200-Dome Casing. 201-Safety Valves. 202-Chime Whistles. 203-Whistle Rig. 204-Ventilator 205-Cab. 206-Air Pump Lubricator. 207-Air Gauge. 208-Steam Gauge. 209-Steam Turret. 210-Injector Throttle. 211-Blower Cock. 212-Gauge Lamp. 213-Signal Whistle. 214-Air Pump Throttle. 215-Throttle Lever. 216-Pneumatic Sander, 216a-Sand Lever. 217-Reverse Lever. 218-Engineer's Brake Valve. 219-Gauge Cocks. 220-Quadrant. 221-Cut Out Valve. 222-Fire Door. 223-Cylinder Cock Lever. 224-Cylinder Lubricator. 225-Oil Can Shelf. 226-Hand Hold. 227-Shake Lever Stub. 228-Ash Pan Damper Handle. 229-Whistle Signal Valve. 230-Brake Valve Reservoir. 231-Train Pipe. 232-Train Pipe Hose. 233-Signal Pipe 234-Signal Pipe Hose. 235-Feed Pipe Hanger. 236-Feed Pipe. 237-Feed Pipe Hose. 238-Tall Piece of Frame. 239-Cab Bracket 240-Counterbalance Weight.

# ACTION OF STEAM IN OPERATING LOCOMOTIVE

**General Course of Steam.** One of the most important features in locomotive operation is the action of the steam in transmitting the heat energy liberated in the fire-box to the driving wheels in the form of mechanical energy. It is therefore important that we should have a clear understanding, in the beginning, of the various changes which occur while the steam is passing from the boiler to the atmosphere in performing its different functions. In making this study it will prove of much assistance if reference is made to [Fig. 32.](#) (See [page 27](#) for figure and associated index).

Before this is done, however, a brief statement of the characteristics of steam and the precautions which must be taken as the steam passes through the cylinder may not be out of place. At normal pressure water boils at 212° F., but with an increase of pressure the boiling temperature and the consequent temperature of the steam rises. Now if the steam formed at 212° F. and atmospheric pressure were passed into the cool steam chest and later into the cylinder, it would become cooled below 212° F., would condense, and would therefore lose its power. To avoid this possibility, the steam is generated in the boiler at a high pressure so that, when allowed to expand into the cylinder and lose some of its energy by virtue of the work it has done on the piston, the temperature is still *above* the condensation temperature for the pressure under which it is acting.

With this in mind let us follow the steam in its path and note the changes to which it is subject and the direct results of its action. When the throttle is opened the steam, which is generated in the boiler and there held at high pressure, enters the dry pipe at a point near the top of the dome and flows forward to the smokebox, where it enters the T-head and is conducted downward on either side into the steam chest and ultimately through the cylinders and out through the exhaust to the atmosphere.

**Steam Enters Steam Chest.** At the very outset when the throttle valve is opened and steam enters the dry pipe, a change takes place. This change is a loss in pressure; for when the steam reaches the steam chest its pressure is reduced several pounds per square inch, as evidenced by gages placed on the boiler and steam chest or by steam chest diagrams taken simultaneously with the regular cylinder diagrams. This pressure drop would not appear were it not for the fact that the locomotive is set into motion at the opening of the throttle. Consequently, motion is transmitted to the steam in the various pipes and passages, and the frictional resistance offered retards its flow, with the result that a pressure less than that in the boiler is maintained. The exact amount of this pressure drop depends upon the throttle opening and the rate at which steam is drawn off. This latter feature is a function of the engine speed, which in a measure depends upon the opening of the throttle. Under all conditions, so long as the locomotive is in motion, the pressure in the steam chest will be less than that in the boiler.

**Steam Enters Cylinder.** The steam, after reaching the steam chest, is admitted alternately to first one end of the cylinder then the other through the action of the valve. The opening and closing of the valve is a continuous process, the amount of opening increasing from zero to a maximum and then decreasing to zero. Because of this fact there will be two periods of wire drawing during each admission, independent of the fact that there may or may not be wire drawing during the period of maximum opening. This

action causes a further drop in pressure when the steam finally gets into the cylinder, which loss increases with the speed of the engine.

**Steam in Cylinder.** After the steam reaches the cylinder it experiences a still further loss caused by condensation due to the comparatively cool cylinder walls, heads, and piston. This loss can be minimized to a limited extent by the use of an efficient lagging but it can never be entirely eliminated. Even if there were no loss in the cylinder due to radiation, there still would be a loss because of the exhaust, which occurs at a temperature much lower than that of the entering steam and which would cool the cylinder walls and parts to at least the average temperature of the steam in the cylinder during the stroke.

When the steam expands in the cylinder in the performance of its work still another drop in pressure occurs, the amount depending upon the point of cut-off. As this can be varied at the will of the operator, it can be seen that the pressure drop can be very great or very small. During this portion of its travel the steam does its first useful work since leaving the boiler. The steam while in the steam chest exerts a pressure on the valve which causes friction and thereby absorbs a portion of the useful work generated by the action of the steam on the piston.

The steam acting on the piston and causing it to move produces rotation of the driving wheels through the medium of the connecting rod, crank-pin, and various other parts, with an effort which varies throughout the stroke owing to the expansion of the steam, the exhaust and compression, which is taking place on the opposite side of the piston, and the angularity of the connecting rod. The pressure on the guides, due to the angularity of the connecting rod, causes friction which reduces the effectiveness of the work done on the piston. The effect of the inertia of the parts at high rotative speeds affects the thrust on the crank-pin to a marked degree. These points and many others which might be mentioned are of much importance in the study of the locomotive and its ability to do useful work in hauling trains.

**Steam after Leaving Cylinder.** The steam having pushed the piston to the end of its stroke is exhausted on the return stroke, but at a slight back pressure, which opposes the effectiveness of the return stroke and results in a direct loss. The closing of the valve before the completion of the return stroke causes an additional resistance in compressing the steam remaining in the cylinder, but this is not without some advantage. The steam in being exhausted from the cylinder is discharged into the exhaust cavity in the cylinder and from thence into the exhaust passage in the cylinder saddle and out through the exhaust nozzle into the smoke-box. At this point the steam is very much reduced in pressure but, owing to its relatively high velocity, as it leaves the exhaust nozzle and enters the stack, it is still able to do useful work by producing a slight vacuum in the smoke-box in an ejector-like action. The useful work performed is not in the way of moving the machine but in increasing the rate of combustion in the fire-box. The action is such as to cause a rate of combustion unequalled in any other form of steam power plant with the exception, perhaps, of the steam fire engine which a few years ago was so popular.

# LOCOMOTIVE BOILERS

Before entering into the details of the various elements comprising a locomotive, it is thought advisable to give them some study in order to become familiar with the names of the various parts and their relation to each other. [Fig. 32](#) (See [page 27](#) for figure and associated index) is given for this purpose and represents a longitudinal section of a 440 type locomotive with all parts numbered and named. This figure should be carefully studied in order that the future work of the text may be clearly understood.

A *locomotive boiler* may be defined as a steel shell containing water which is converted into steam, by the heat of the fire in the firebox, to furnish energy to move the locomotive.

Locomotive boilers are of the internal fire-box, straight fire-tube type having a cylindrical shell containing the flues and an enlarged back-end for the fire-box, and an extension front-end or smoke-box leading out from which is the stack.

**Classification of Boilers as to Form.** Locomotive boilers are classified as to form as follows:

*Straight top*, [Fig. 33](#), which has a cylindrical shell of uniform diameter from the fire-box to the smoke-box.

*Wagon top*, [Fig. 34](#), which has a conical or sloping course of plates next to the fire-box and tapering down to the circular courses.

*Extended wagon top*, [Fig. 35](#), which has one or more circular courses between the fire-box and the sloping courses which taper to the diameter of the main shell.

**Classification of Boilers as to Fire-Box Used.** Boilers are frequently referred to also and designated by the type of fire-box contained, such as *Belpaire*, *Wooten*, and *Vanderbilt*. This designation does not in any way conflict with the classification of different types of boilers already given but refers to the general character of the fire-box; that is, the boiler may be classified as a straight top boiler and at the same time a Wooten fire-box. Since this is true it is necessary to know the distinction between the Belpaire, the Wooten, and the Vanderbilt types of fire-box.

The *Belpaire boiler*, as illustrated in [Fig. 36](#), has a fire-box with a flat crown sheet *A* jointed to the side sheets *B* by a curve of short radius. The outside sheet *C* and the upper part of the outside sheets *D* are flat and parallel to those of the fire-box. These flat parallel plates are stayed by vertical and transverse stays and obviate the necessity of crown bars to support and strengthen the crown sheet. The advantage gained is that the stay bolts holding the crown and side sheets can be placed at right angles to the sheets into which they are screwed.

The *Vanderbilt fire-box* is built of corrugated forms, as illustrated in [Fig. 37](#). The principal object in the design of this fire-box is to eliminate stay bolts which are a source of much trouble and expense in keeping up repairs. Only a few locomotives fitted with this type of fire-box have been used.

The *Wooten fire-box*, so-called, obtained its name from the designer. This form of fire-box extends out over the frames and driving wheels, as may be seen from [Fig. 38](#). It was designed for the purpose of burning fine anthracite coal but soon after its introduction it found favor with a few railroads using bituminous coal. The drawing shown in [Fig. 39](#)

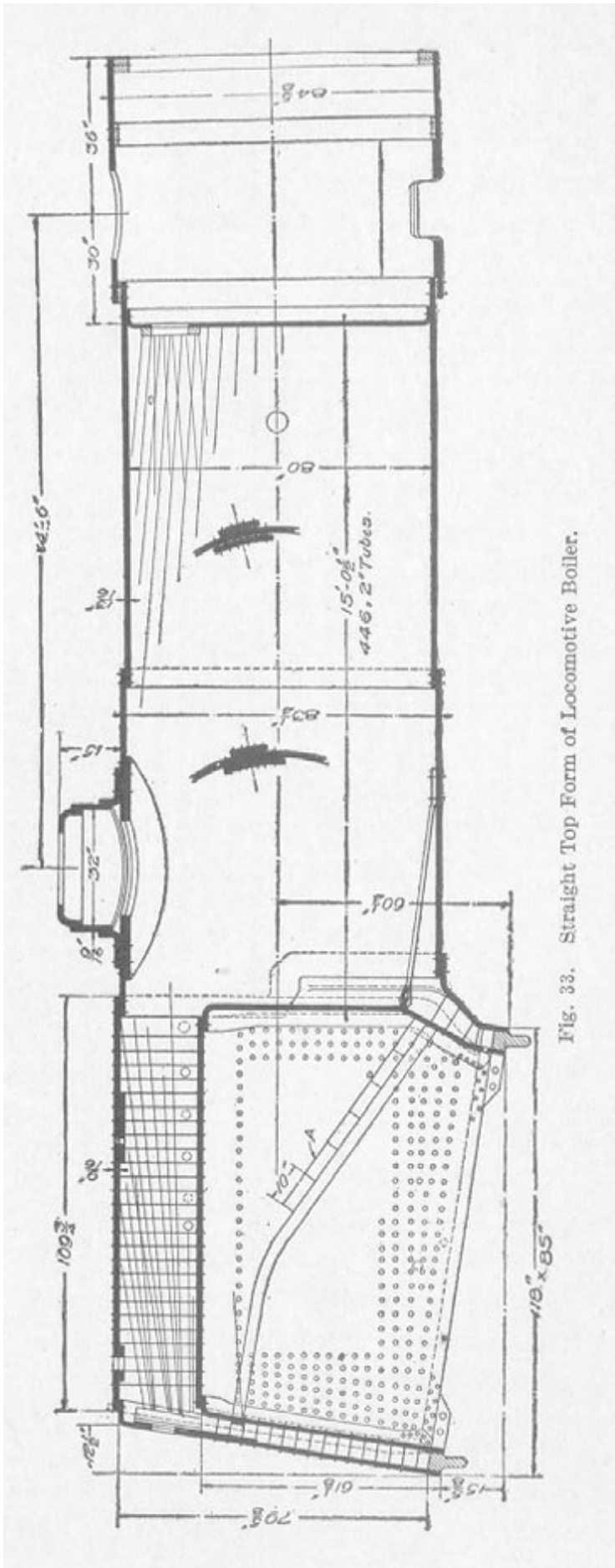

Fig. 33. Straight Top Form of Locomotive Boiler.

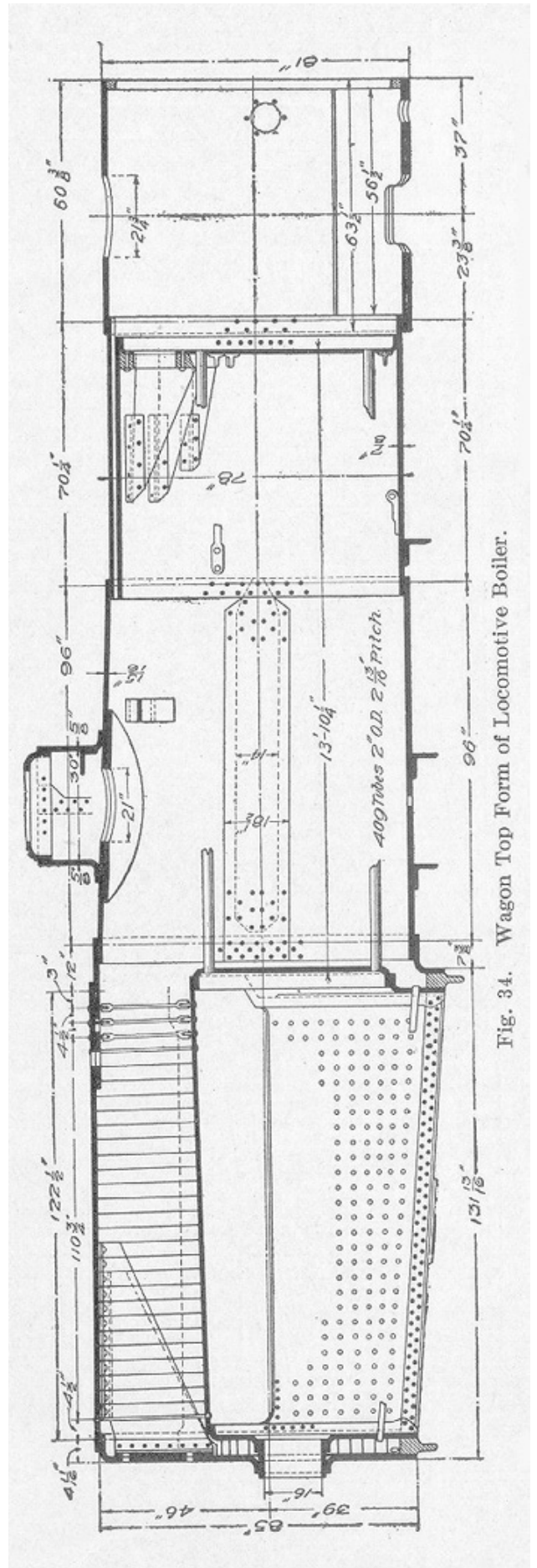

Fig. 34. Wagon Top Form of Locomotive Boiler.



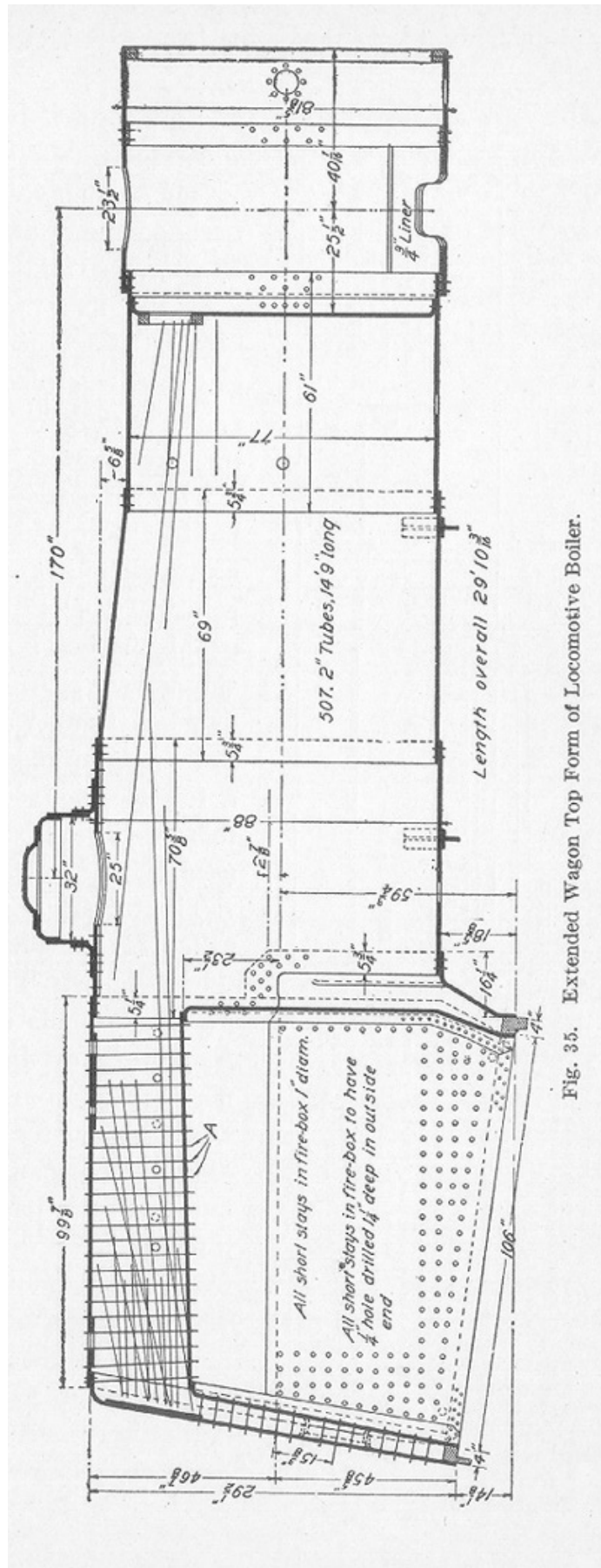

Fig. 35. Extended Wagon Top Form of Locomotive Boiler.

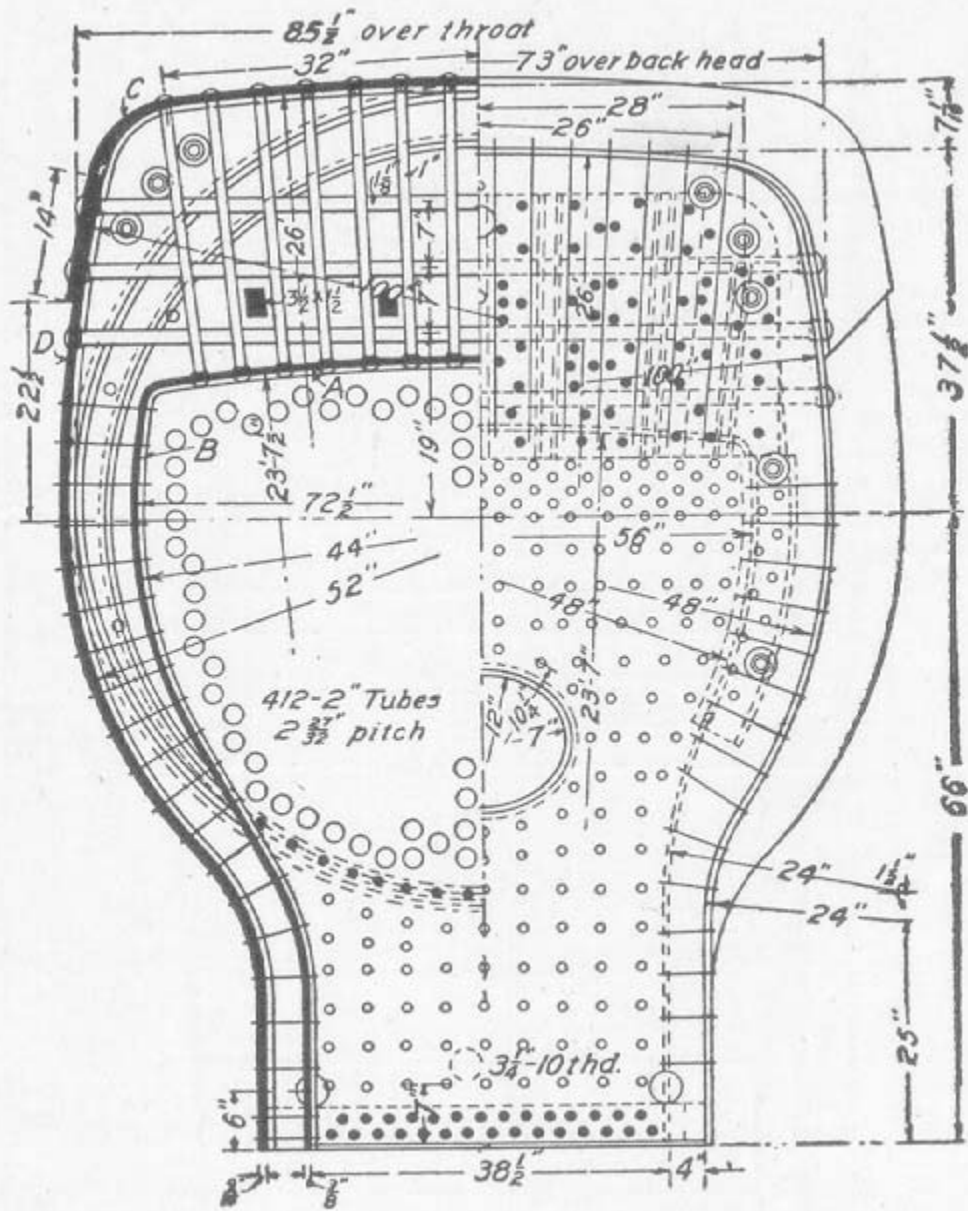

Fig. 36. Belpaire Boiler.

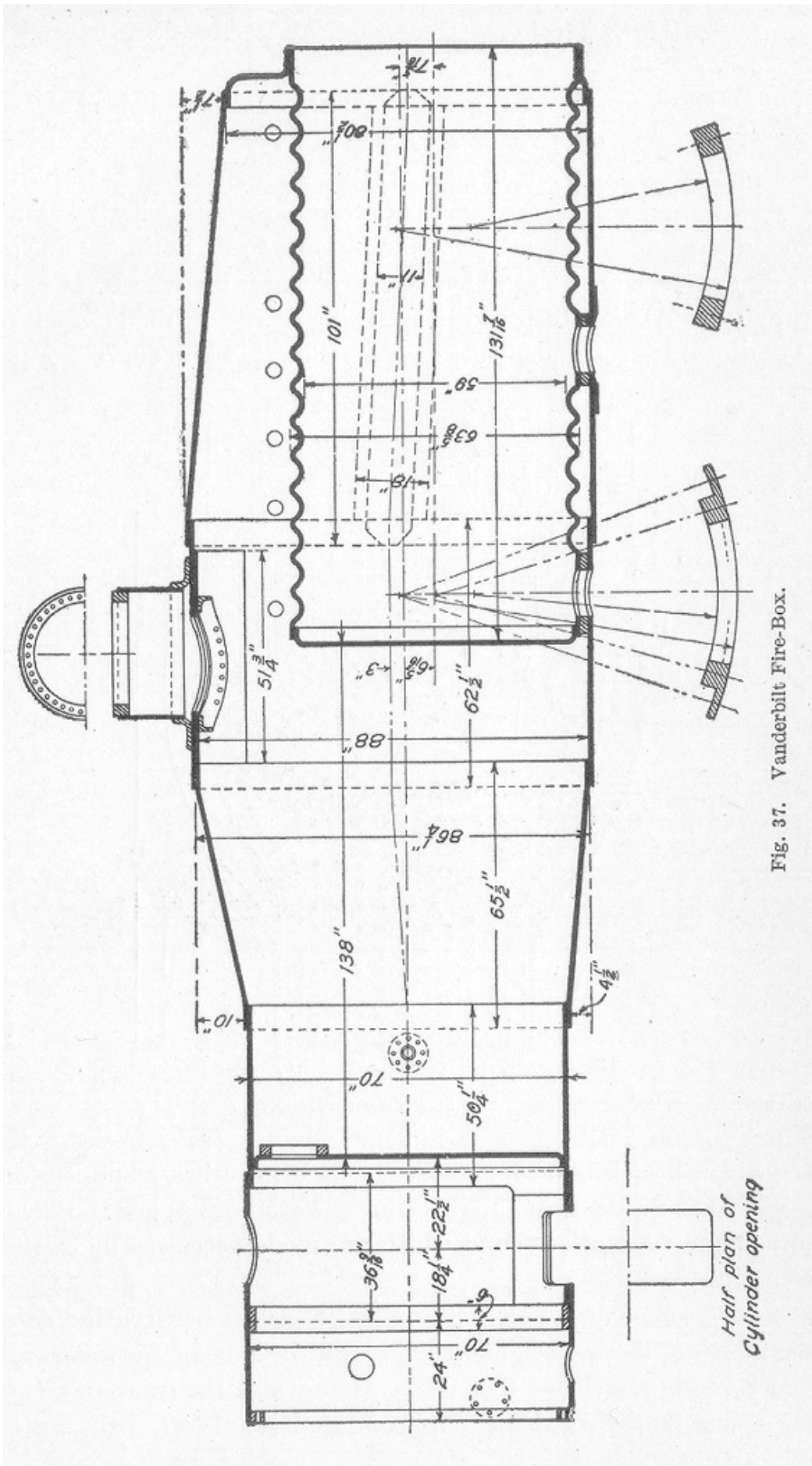

Fig. 37. Vanderbilt Fire-Box.

illustrates its general construction. It has rendered good service in certain localities but has never been very extensively used. In addition to the designations given the various boilers already mentioned, they are frequently spoken of as narrow or wide fire-box locomotives. A *narrow fire-box* is one which is placed between the frames or may rest on the frames between the driving wheels. These conditions limited the width of the fire-box from 34 to 42 inches. *Wide fireboxes* are those which extend out over the wheels, as is the

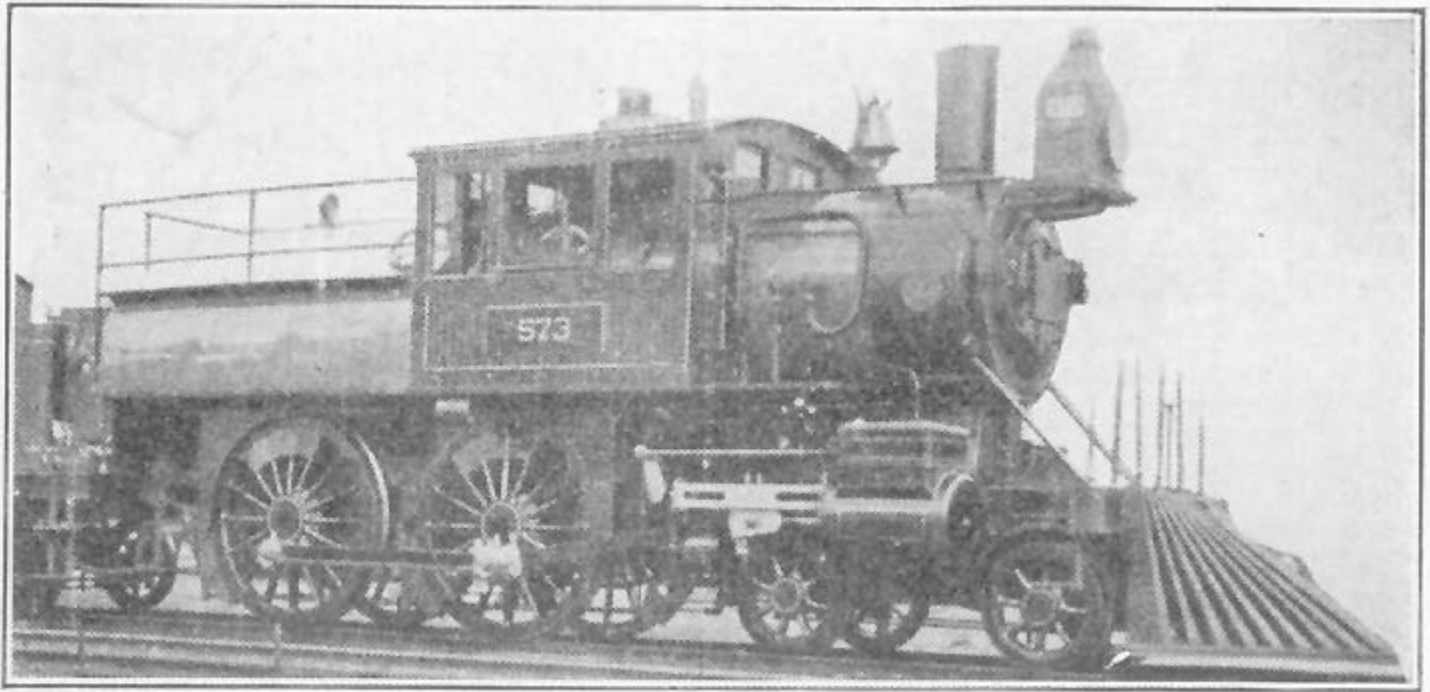

Fig. 38. Engine with Wooten Fire-Box.

case in the Wooten, their width only being limited by road clearances. The dimensions commonly used are as follows: width 66, 76, 85, 103, and 109 inches; length 85, 97, 103, 115, and 121 inches, all dimensions being taken inside of the fire-box ring. Variations above and below these figures are often found which are made necessary by existing conditions.

In locomotives where the fire-box is placed between the axles, the length of the fire-box is limited by the distance between the axles and is rarely more than 6 or 9 feet, from which the front and back legs must be deducted. Placing the fire-box on top of the frames makes any length possible, the length being governed by the capability of the fireman to throw the coal to the front end of the fire-box.

**Flues.** From the sectional view of the boiler illustrated in [Fig. 32](#) (See [page 27](#) for figure and associated index) and [Fig. 44](#), it is evident that a large part of the boiler is composed of flues or tubes. The flues give to the boiler the largest part of its heating surface. It is the flues which largely affect the life of the boiler and, therefore, the life of the locomotive, for this reason it is quite necessary to properly install and maintain them. A large amount of the repair costs is directly traceable to the flues. This is especially true in localities where water is found which causes scale to form on the flues from 1/16 to 1/2 inch in thickness, thus causing unequal expansion and contraction and overheating. These

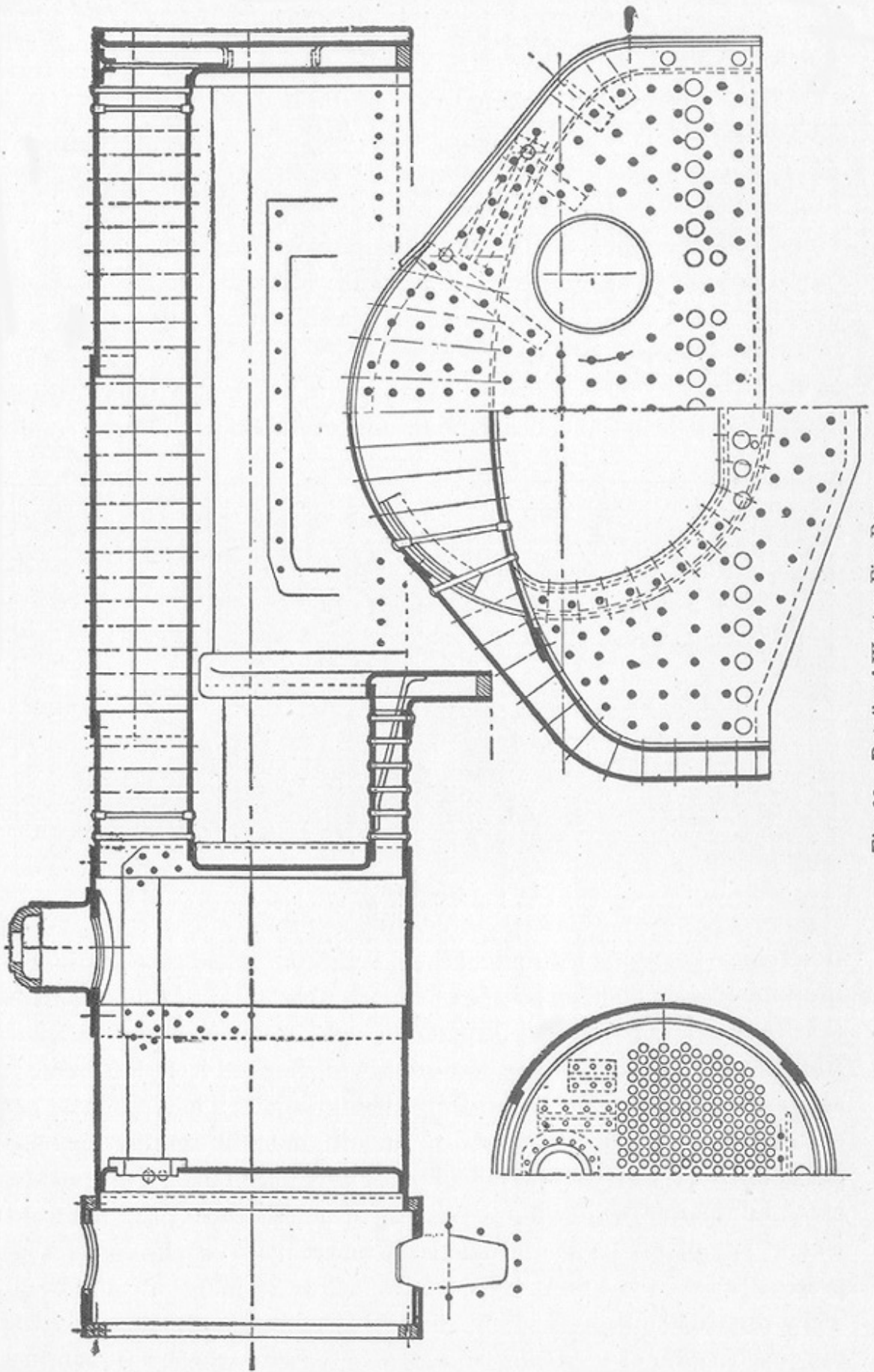

Fig. 39. Details of Wooten Fire-Box.



conditions cause the joints to break at the flue sheets. Cold air entering the fire-box door is another source of flue trouble. It is to these details that careful attention must be given in order to alleviate flue failures. Flues should be made of the best quality of charcoal iron, lap-welded, and subjected to severe tests before being used. They must be accurately made, perfectly round and smooth, must fill standard gauges perfectly, must be free from defects such as cracks, blisters, pits, welds, etc., and must be uniform in thickness throughout except at the weld where  $2/100$  of an inch additional thickness may be allowed. The present practice is to use tubes of from 2 to  $21\frac{1}{4}$  inches in diameter. They vary in length from about 15 to 20 feet, the length depending on the construction of the boiler and locomotive as a whole. The tubes are supported at each end by letting them extend through the tube sheets. It is in the setting of the tubes that great care should be exercised. The tube sheets must be carefully aligned and the hole drilled through and reamed. These holes are usually made  $1/16$  of an inch larger in diameter than the outside diameter of the tubes. The tubes should be made not less than  $1/4$  nor more than  $3/8$  inch longer than the gauge distance over the front and back flue sheets. All back ends of tubes should be turned and beaded, and at least ten per cent of those in the front end. The number of tubes used varies according to the type and size of the locomotive but usually from 300 to 500 are employed. The flue sheets are made thicker than the other sheets of the boiler in order to give as wide a bearing surface for the tubes as possible. They are usually  $5/8$  inch thick. The flue sheets are braced or stayed by the flues and by diagonal braces fastened to the cylindrical shell. The bridges or metal in the flue sheets between two adjacent flues are usually made from  $3/4$  to 1 inch in width. The greater the width of the bridges, the greater the space between the flues; therefore, better circulation will be obtained.

**Stay-Bolts.** The universal method of staying flat surfaces of the fire-box at the sides and front is by the use of stay-bolts. These stay-bolts are screwed through the two sheets of the fire-box and are riveted over on both ends. [Fig. 40](#) illustrates a stay-bolt screwed into position and represents a strong and serviceable form. The stay-bolt is cut away between the sheets and only sufficient thread is cut at the ends to give it a hold in the metal. In [Fig. 40](#), *A* represents the inside sheet or the one next to the fire, and *B* represents the outside sheet. A small hole *C* is drilled into the outside end of the stay-bolt. This is known as the *tell-tale hole* and will permit the escape of water and steam should the bolt become broken.

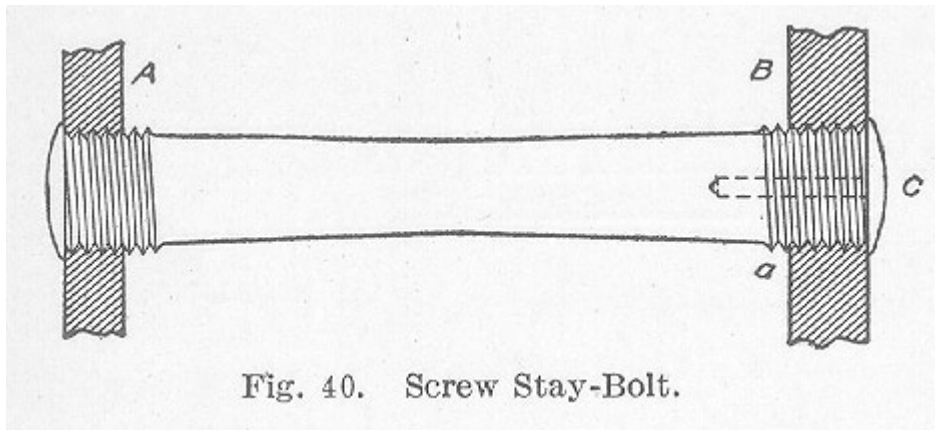

Fig. 40. Screw Stay-Bolt.

This tell-tale hole is usually  $3/16$  of an inch in diameter and  $1\frac{1}{4}$  inches deep and is drilled at the outer end of the stay-bolt, since almost invariably the fracture occurs near the outer sheet. All boiler stay-bolts, including radial stays, have 12 Whitworth standard threads per inch. The most common cause of stay-bolts breaking is the bending at the point *B*, [Fig. 40](#), due to the expansion of the sheets *A* and *B*. The sheet *A*, being next to

the fire, is kept at a much higher temperature while the boiler is at work than the sheet *B*, which is subjected to the comparatively cool temperature of the atmosphere. This causes the plates *A* and *B* to have a movement relative to each other due to unequal expansion. The breakage is greatest at points where the greatest amount of movement takes place. As the two sheets are rigidly fastened to the mud ring, it is evident that the variation of expansion must start from that point; hence, the greatest vertical variation will be found at the top of the fire-box. In like manner, the back heads are securely fastened by stay-bolts so that horizontal variation must start at the back end; consequently the greatest horizontal variation will be found at the front end of the fire-box. The result of these two expansions will, therefore, be greatest at the upper portion of the front end. It is there that the greatest number of stay-bolt breakages occur.

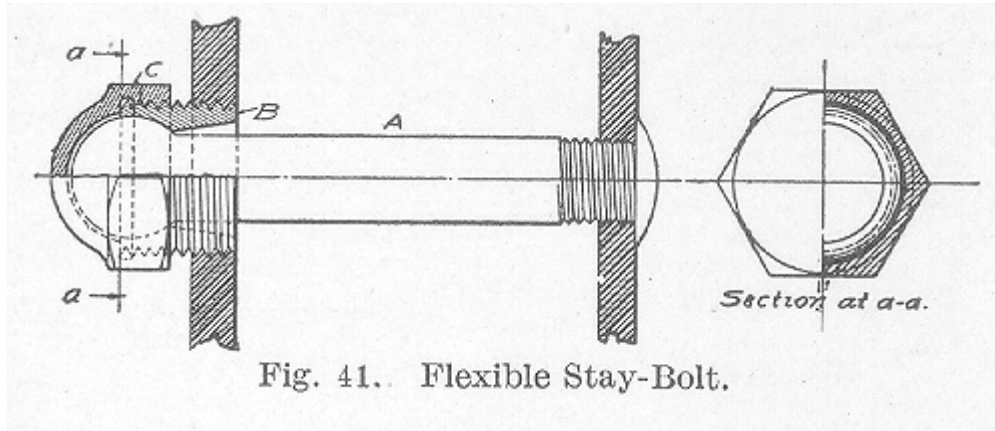

Fig. 41. Flexible Stay-Bolt.

In order to avoid these bending stresses, a number of different forms of flexible stay-bolts have been designed. One form of these is shown in [Fig. 41](#). The stay-bolt proper, *A*, has a ball formed on one end and a thread cut on the other. A plug *B* sets over the ball and forms a socket in which the latter can turn. As the stay-bolt is free to revolve in the plug, there is no necessity of the thread of the stay-bolt being cut in unison with the thread on the plug. Such a stay-bolt as this permits the inner sheet of the fire-box to move to and fro relative to the outer sheet without bending the outer end of the stay-bolt. Flexible stay-bolts when used are placed in what is known as the *zone of fracture*. [Fig. 42](#) and [Fig. 43](#) illustrate the application of flexible stay-bolts to a wide fire-box. [Fig. 42](#) shows five rows of flexible stay-bolts at each end of the fire-box and four rows at the bottom parallel to the mud ring. It should be remembered, however, that this is one installation only and that the arrangement in all cases may vary but this illustration is representative of good practice. Another illustration is shown in [Fig. 45](#). Here the flexible stay-bolts are shown by shaded circles. It is evident from [Fig. 43](#) that all the stays in the throat sheet are flexible, which is a very good arrangement since the stay-bolts in the throat sheet are subjected to very severe strains. On some railroads, flexible stay-bolts are put in the fire-box door sheets but this practice varies in some details for different roads.

Stay-bolts should be made of the best quality double refined iron free from steel, having a tensile strength of not less than 48,000 pounds per square inch. The bars must be straight, smooth, free from cinder pits, blisters, seams, or other imperfections. The common practice is to use stay-bolts 7/8 or 1 inch in diameter spaced about 4 inches from center to center.

Stay-bolt breakage is very large in bad water districts and gives a great deal of trouble on most railroads. The stay-bolt problem, therefore, is a very important one.



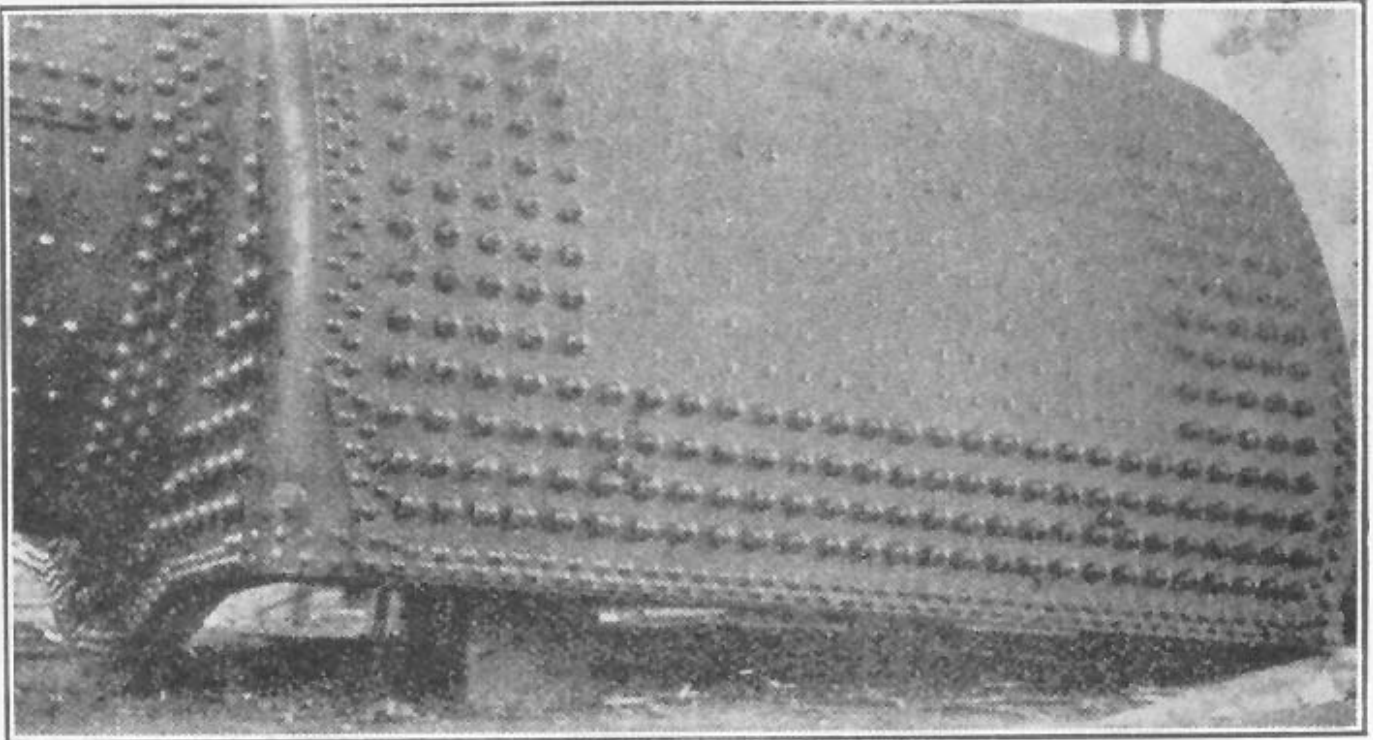

Fig. 42. Boiler, Showing Use of Flexible Stay-Bolts.

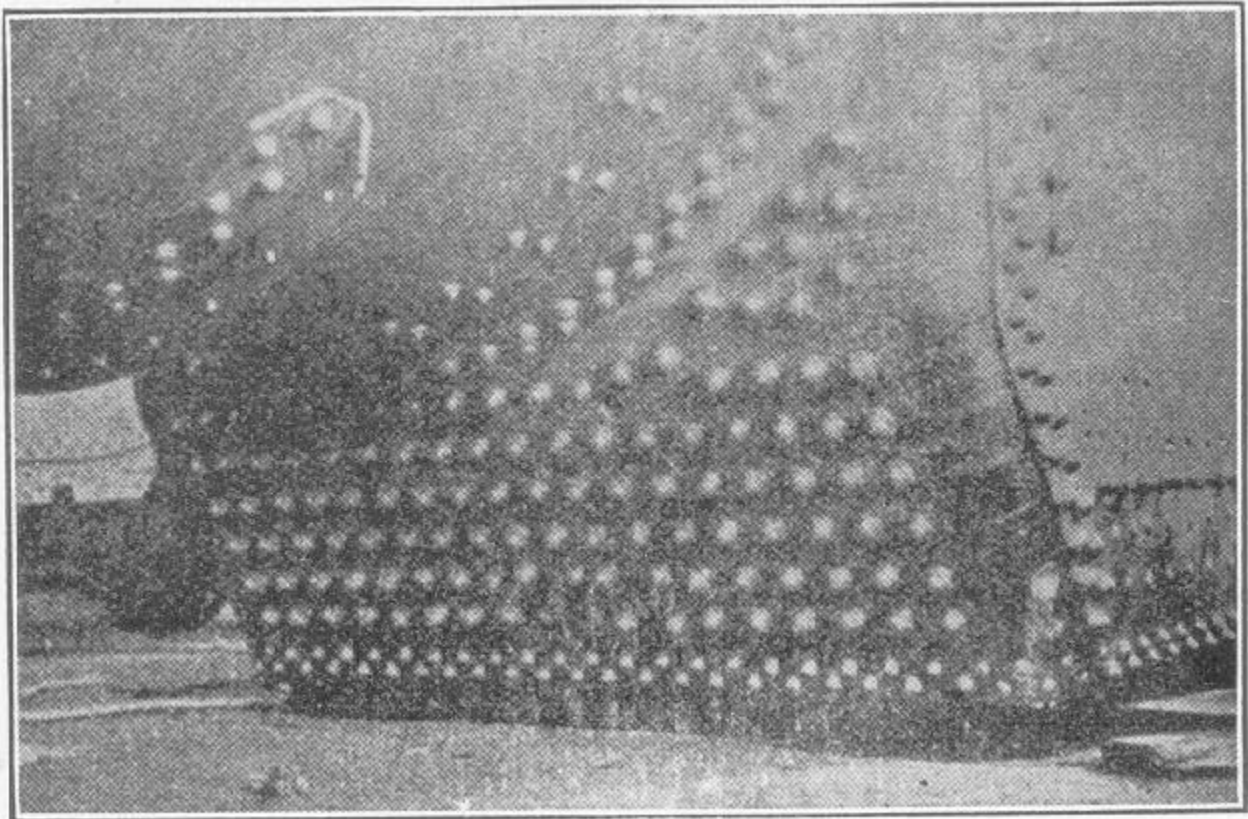

Fig. 43. Boiler, Showing Use of Flexible Stay-Bolts.

In addition to staying the sides and front and back ends, it is also necessary to stay the crown sheet. To accomplish this two general methods have been used. The oldest of these, by the use of crown bars, has almost passed out of service and well it is because of the many objectionable features it possessed. In this method, a number of crown bars were used which were supported by the edges of the side sheets and which were held

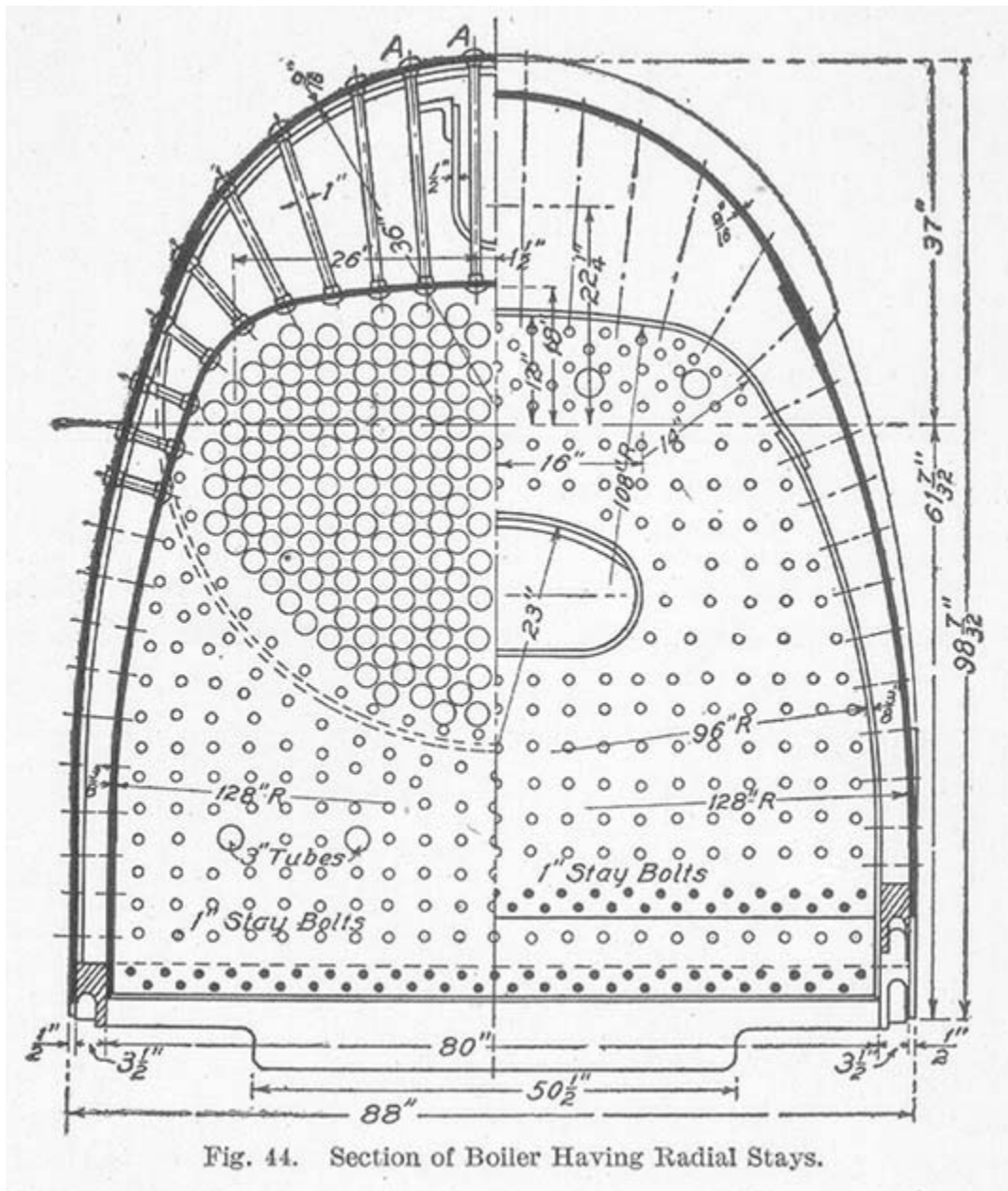

Fig. 44. Section of Boiler Having Radial Stays.

apart by spacers resting upon the crown sheet and to which the crown bars were tied by bolts. The crown sheet was supported by stay-bolts which were bolted to the crown bars. A great deal of the space over the crown sheet was taken up by these crown bars which greatly interfered with the circulation and made it very difficult in cleaning. The second method of staying the crown sheet is by means of radial stays. All stay-bolts over 8 inches in length are usually classified as radial stays. Radial stay-bolts are of the same general type and material as the stay-bolts already described, and are put in on radial lines; hence their name. [Fig. 44](#) shows a section of a boiler having radial stays *A*. These stays extend around the curved surface of the fire-box from the back to within two or

three rows of the front end as illustrated at *A*, [Fig. 45](#). The stays *B* in [Fig. 45](#) are of a different form and are frequently used in the front end to allow for expansion and contraction of the flue sheet. These extend around to the curved surface in the same manner as do the radial stays shown in [Fig. 44](#).

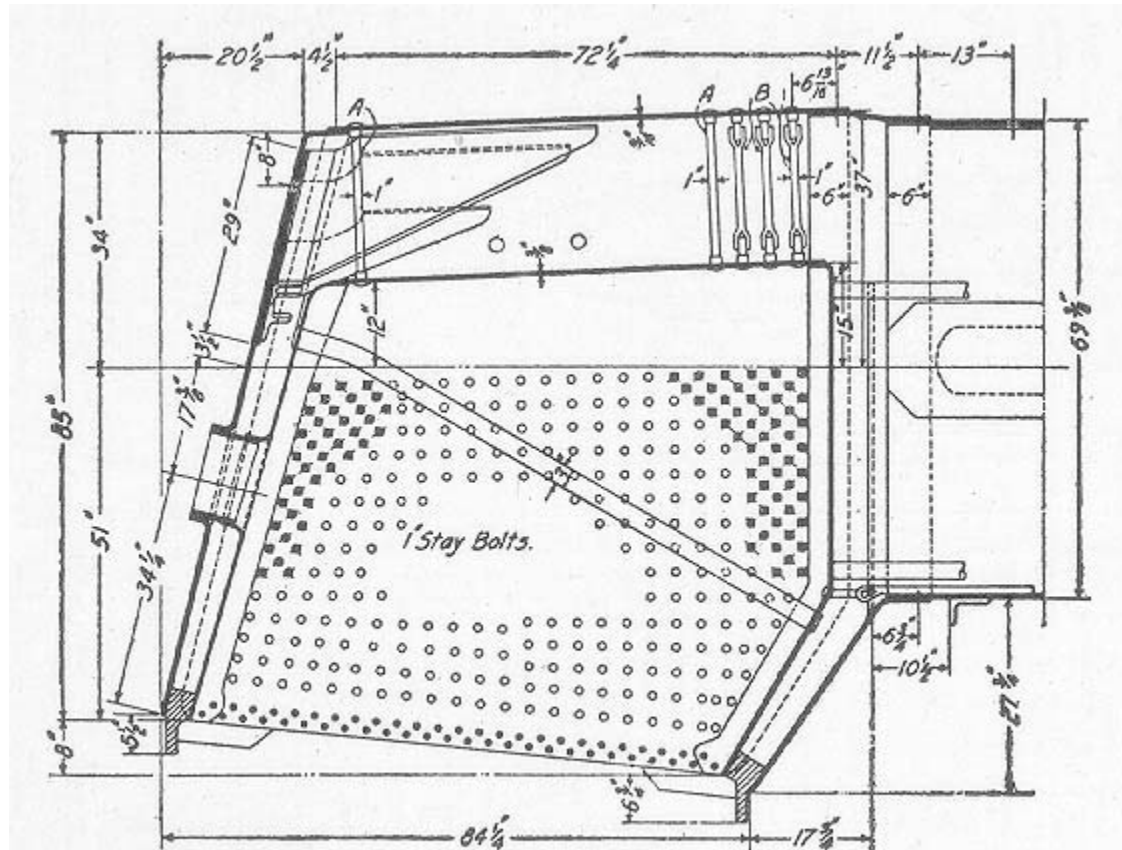

Fig. 45. Section Showing Two Types of Stays.

All radial stays should have enlarged ends with bodies  $\frac{3}{16}$  inch smaller in diameter than the outside diameter of thread. They should be made with button heads and should have threads under heads increased in diameter by giving the end a taper  $\frac{1}{2}$  inch in 12 inches. Radial stays commonly used are 1 inch,  $1 \frac{1}{8}$  inch, and  $1 \frac{1}{4}$  inch in diameter at the ends. The allowable safe fiber stress is 4,500 pounds per square inch.

**Grates.** The grate is made up of a set of parallel bars at the bottom of the fire-box, which hold the fuel. These bars are commonly made of cast iron and constructed in sections of three or four bars each. They are supported at their ends by resting upon a frame and are connected by rods to a lever which can be moved back and forth to rack the bars and shake ashes and cinders out of the fire. A drawing of such a grate is illustrated in [Fig. 46](#). When the grates occupy the full length of the fire-box they are divided into three sections, any one of which can be moved by itself. In the burning of anthracite coal, *water grates* are commonly used, a type of which is illustrated in [Fig. 47](#) and [Fig. 48](#). In [Fig. 47](#), the grate is formed of a tube *a* expanded into the back sheets of the fire-box and inclined downward to the front in order to insure a circulation of water. Opposite the back opening, a plug is screwed into the outer sheet which affords a means whereby the tube may be cleaned and a new one inserted in position if a repair is needed. At the front end,



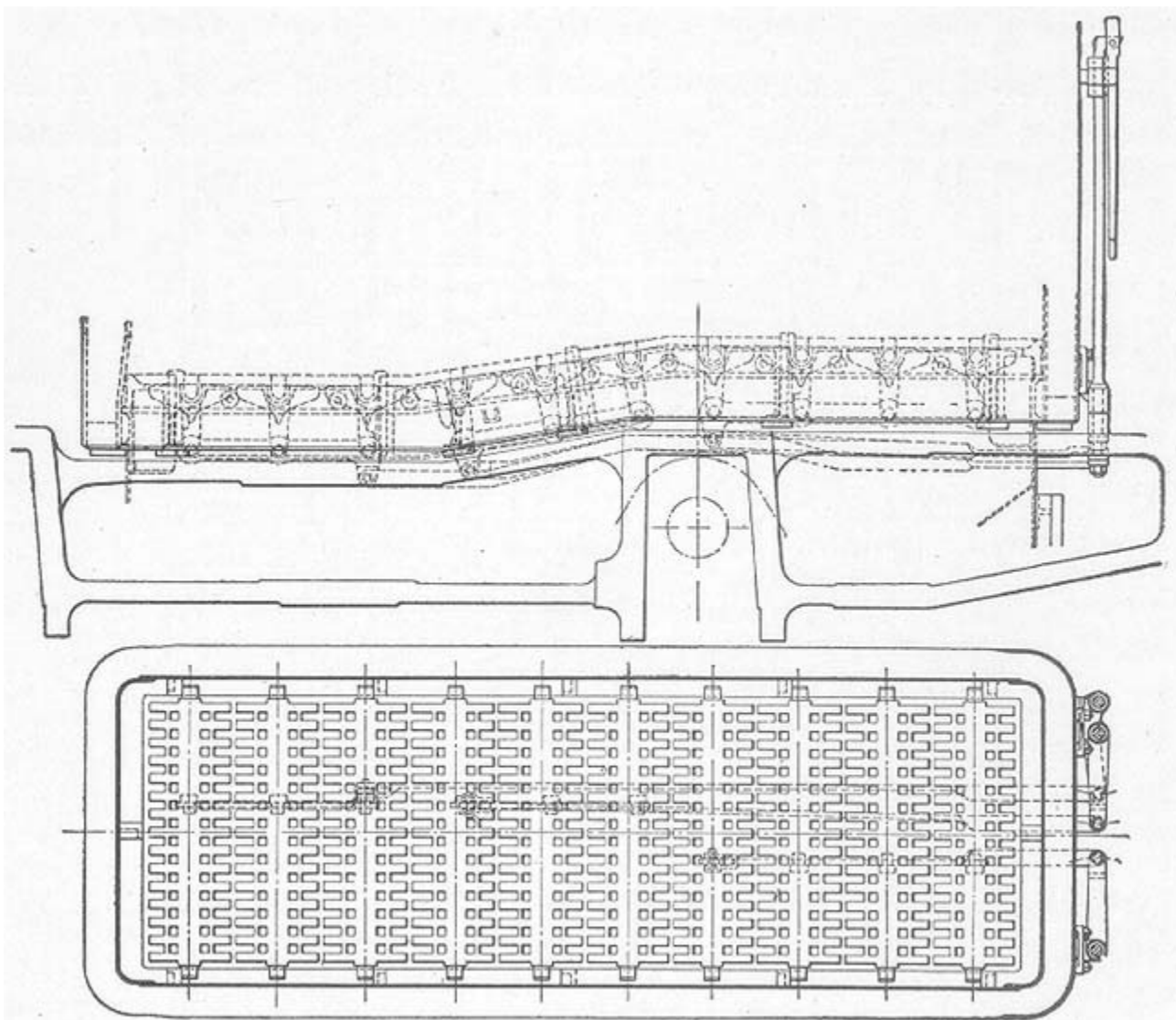

Fig. 46. Elevation and Plan of Grate.

the tube is usually screwed into the flue sheet. Water grates are rarely used alone but usually have spaced between them plain bars. These bars pass through tubes expanded into the sheets of the back water leg and by turning them, the fire may be shaken; and by withdrawing them, it may be dumped. [Fig. 48](#) shows a cross-section of the arrangement usually employed. In this figure, *A* represents the water tube and *B*, the grate bars.

**Ash Pans.** Ash pans are suspended beneath the fire-box for the purpose of catching and carrying the ashes and coal that may drop between the grate bars. They are made of sheet steel. [Fig. 49](#) illustrates a longitudinal section of an ash pan commonly used in fire-boxes placed between the axles of the engine. It is provided at each end with a damper *a* hinged at the top and which may be opened and set in any desired position in order to regulate the flow of air to the fire. It is quite important that the dampers should be in good condition in order that the admission of air to the fire may be regulated. The total unobstructed air openings in the ash pan need not exceed the total tube area but should not be less than 75 per cent. For many years the type shown in [Fig. 49](#) was almost universally used. More recently, however, a damper capable of better adjustment and more easily kept in condition has been developed. Such a damper is illustrated in [Fig. 50](#).

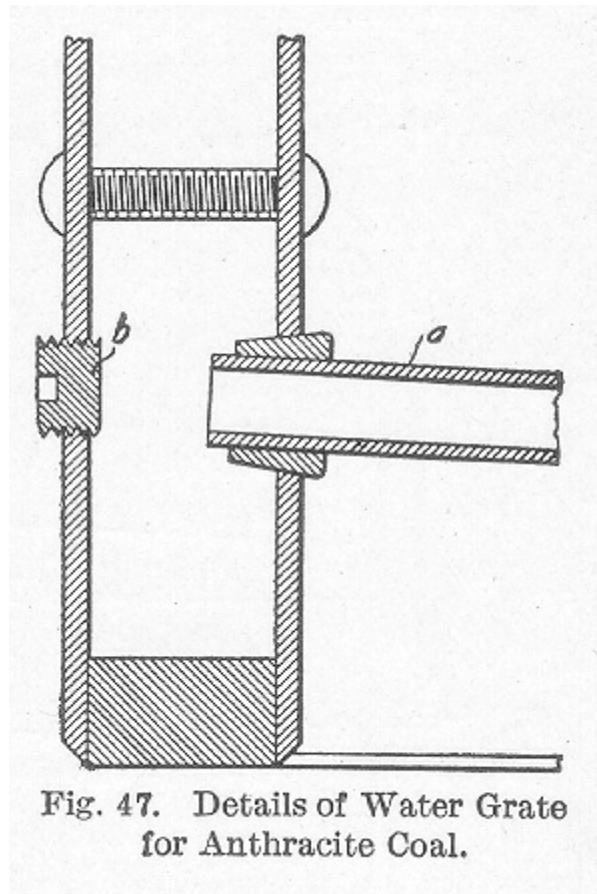

Fig. 47. Details of Water Grate for Anthracite Coal.

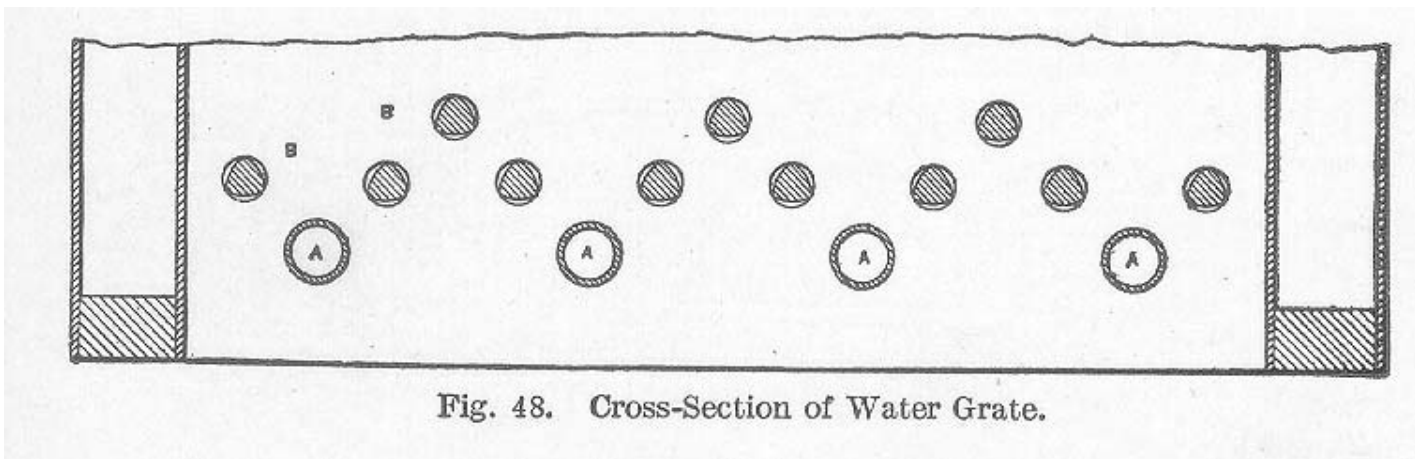

Fig. 48. Cross-Section of Water Grate.

In this type the dampers are placed upon the front faces of the ash pan and are raised and lowered by the contraction of levers and bell cranks. For example, the lifting of the bar *a* turns the bell crank *d* which pulls the connection *c c* which operates the forward bell crank and opens the front damper. In a similar manner, the rear damper *i* may be operated. If these dampers were made of cast iron and work in guides, it is possible to have the construction such that when closed they will be practically air tight.

**Brick Arches.** A brick arch is an arrangement placed in the fire-box to effect a better combustion and to secure a more even distribution of the hot gases in their passage through the tubes. [Fig. 33](#) illustrates a longitudinal section of the fire-box fitted with a brick arch *A*. Its method of action is very simple. It acts as a mixer of the products of combustion with the air and as a reflector of the radiant heat of the fire and the escaping

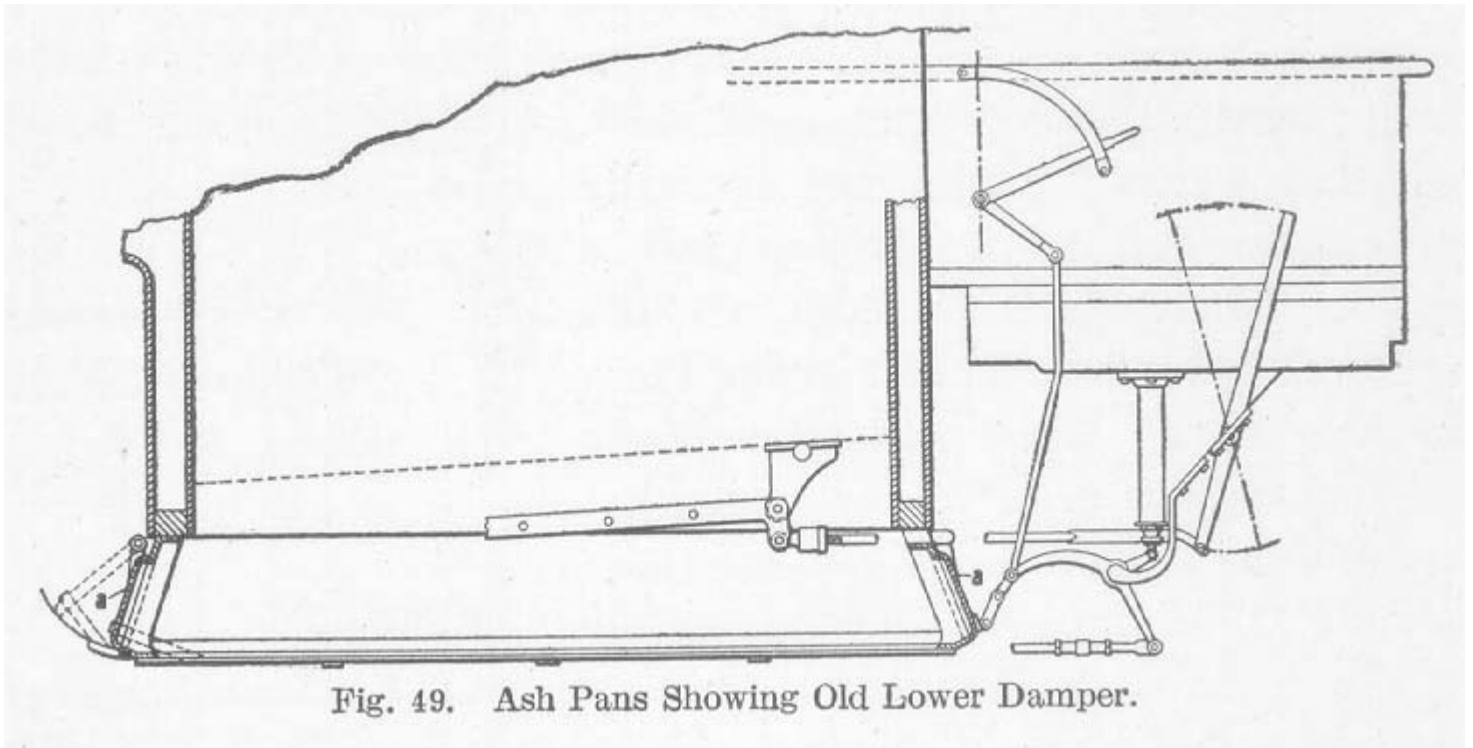

Fig. 49. Ash Pans Showing Old Lower Damper.

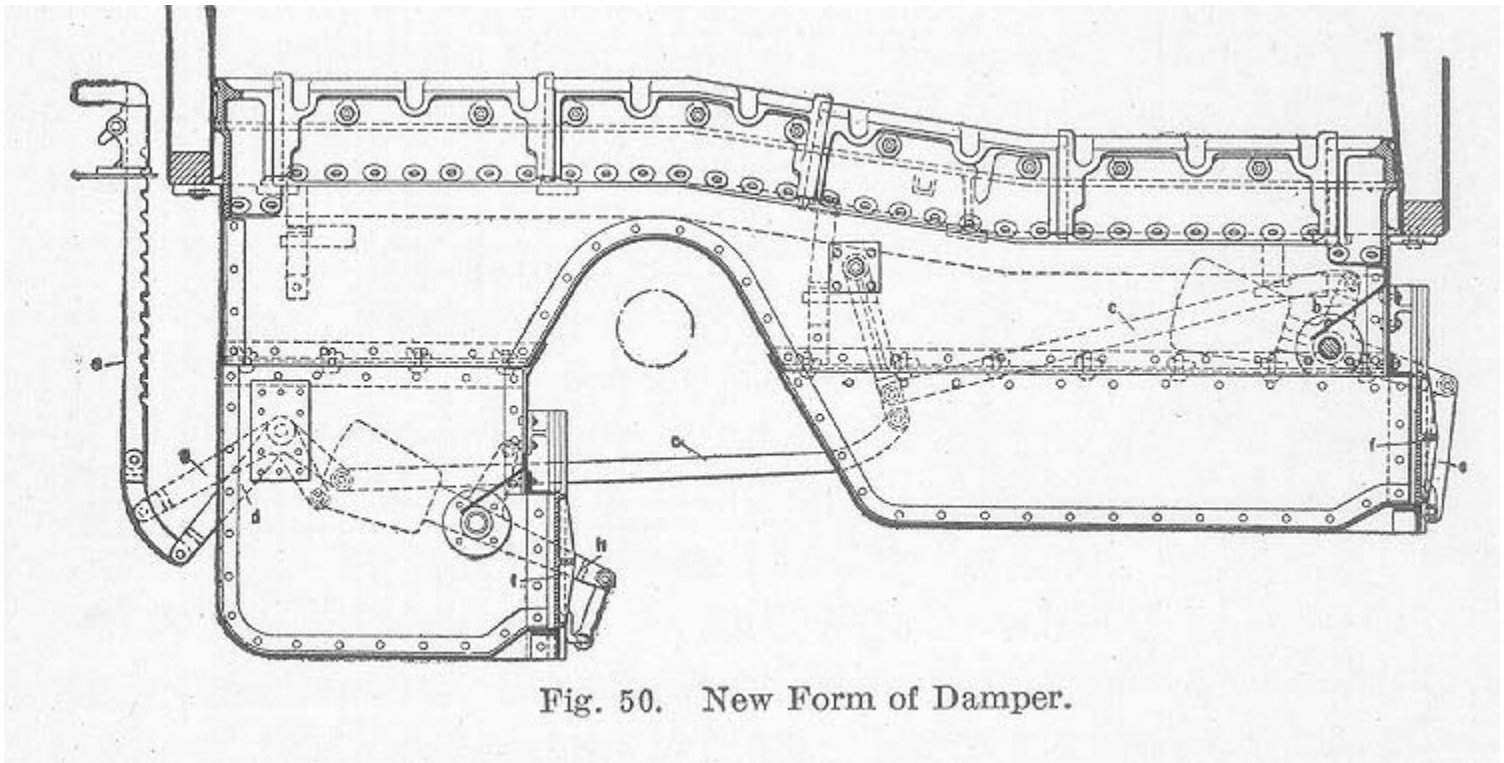

Fig. 50. New Form of Damper.

gases. It is maintained at a very high temperature and in this condition meets the air and gases as they come in contact with it and turns them back to the narrow opening above. By this action it maintains a temperature sufficiently high to burn with the smallest possible quantity of air all the carbonic oxide and the hydrocarbons that arise from the coal. It thus effects a very considerable saving in the cost of running, does away to a great extent with the production of smoke, and develops a high calorific power in comparatively small fire-boxes. This is a valuable property since it is possible for the

boiler to utilize the heat value of the coal to the greatest possible extent. The bricks are usually about 4 or 5 inches thick and are ordinarily supported either by water tubes, as shown in [Fig. 33](#) and [Fig. 45](#), or by brackets in the form of angleirons riveted to the side sheets. The disadvantage accruing from the use of the brick arch is that it is somewhat expensive to maintain because of the rapid deterioration and burning away of the material.

**Smoke-Box and Front End Arrangement.** By the term *front end* is meant all that portion of the boiler beyond the front tube sheet and includes the cylindrical shell of the boiler and all the parts contained therein such as the steam or branch pipes, exhaust nozzle, netting, diaphragm, and draft or petticoat pipes. These parts referred to above are illustrated in the sectional view shown in [Fig. 32](#).

**The Steam or Branch Pipes.** These pipes, 33, follow closely the contour of the shell and connect the T-head, 34, with the steam passage leading to the cylinder and conduct the steam from the dry-pipe to both the right and the left cylinders.

**Exhaust Nozzle.** The exhaust nozzle is the passage through which the steam escapes from the cylinders to the stack.

**Netting.** The netting, 26, is a coarse wire gauze placed in the front end which prevents large cinders from being thrown out by the action of the exhaust and thereby reduces the chances for fires being started along the right of way.

**Diaphragm.** The diaphragm or deflector plate, 27, is an iron plate placed obliquely over a portion of the front end of the flues which deflects the flue gases downward before entering the stack, thus equalizing to a great extent the draft in the different flues. This deflector plate may be adjusted to deflect the gases more or less as desired.

**Draft Pipes.** The petticoat or draft pipes, 36, employed to increase the draft may be used singly or in multiple and raised or lowered as desired.

**Draft.** The front end must be regarded as an apparatus for doing work. It receives power for doing this work from the exhaust steam from the cylinders. The work which it performs consists in drawing air through the ash pan, grates, fire, fire door, and other openings, then continues its work by drawing the gases of combustion through the flues of the boiler into the front end, then forcing them out through the stack into the atmosphere. In order that this work may be accomplished, a pressure less than the atmosphere must be maintained in the smoke-box. This is accomplished through the action of the exhaust jet in the stack. The difference in pressure between the atmosphere and the smoke-box is called *draft*.

Under the conditions of common practice, the exhaust jet does not fill the stack at or near the bottom but touches the stack only when it is very near the top. The action of the exhaust jet is to entrain the gases of the smoke-box. A jet of steam flowing steadily from the exhaust tip when the engine is at rest produces a draft that is in every way similar to that obtained with the engine running. The jet acts to induce motion in the particles of gas which immediately surround it and also to enfold and to entrain the gases which are thus made to mingle with the substance of the jet itself.



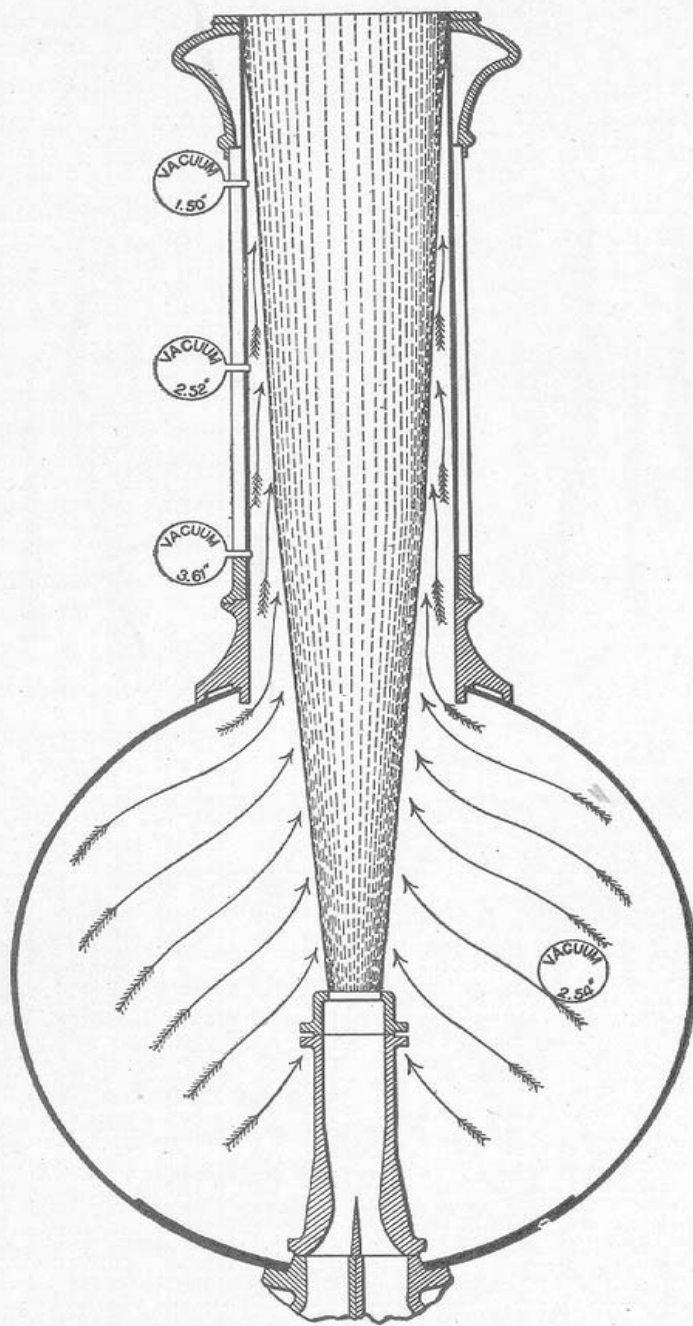

Fig. 51. Section of Exhaust Outlet into Stack, Showing Best Form to Produce Greatest Draft.

The induced action, illustrated in [Fig. 51](#), is by far the most important. The arrows in this figure represent the direction of the currents surrounding the jet. It will be seen that the smoke-box gases tend to move toward the jet and not toward the base of the stack; that is, the jet by the virtue of its high velocity and by its contact with certain surrounding gases gives motion to the particles close about it and these moving on with the jet make room for other particles farther away. As the enveloping stream of gas approaches the top of the stack its velocity increases and it becomes thinner. The vacuum in the stack decreases towards the top. Thus the jet in the upper portion of the stack introduces a vacuum in the lower portion just as the jet as a whole induces a vacuum in the smoke-box. It will be found that the highest vacuum is near the base of the stack. It is higher than the smoke-box on account of the large volume of gas in the latter and it grows less toward the top of the stack. This is illustrated by the different gauges

shown in [Fig. 51](#).

**Exhaust Nozzles.** It has been determined by experiment that the most efficient form of exhaust nozzle is that which keeps the jet in the densest and most compact form. Tests indicate that the nozzle giving the jet the least spread is the most efficient. Of the three forms of exhaust nozzles shown in [Fig. 52](#), the spread of the jet is least for *a* and most for

c. Nozzle *a* ends in a plain cylindrical portion 2 inches in length. Nozzle *c* is contracted in the form of a plain cylinder ending in an abrupt cylindrical contraction. It has been common practice, in cases where engines refuse to steam properly, to put across the

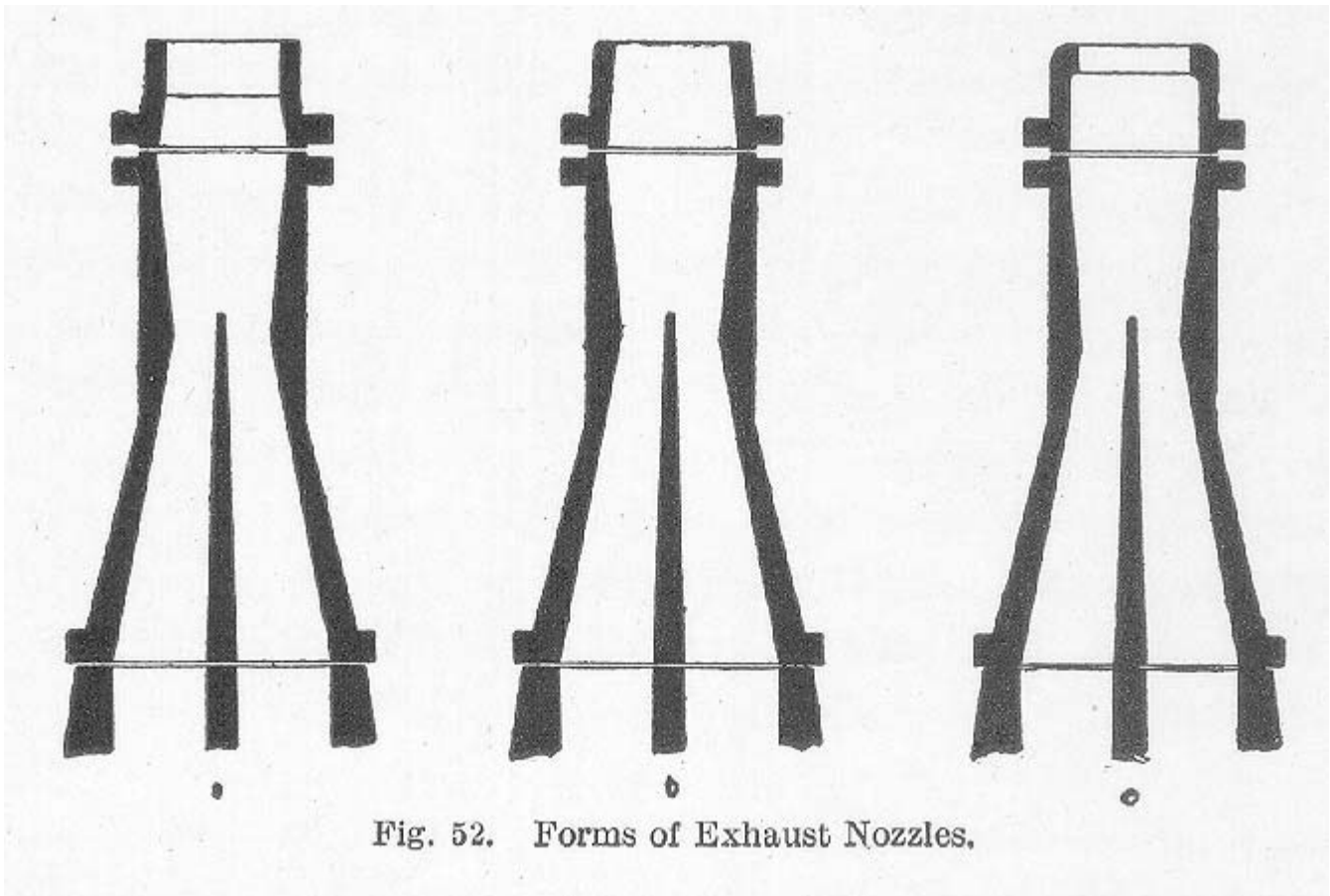

Fig. 52. Forms of Exhaust Nozzles.

exhaust nozzles round or knife-shaped bridges as indicated in [Fig. 53](#). The use of bridges accomplishes the desired result but experiments have shown that this method materially affects the efficiency of the engine because of the increase of back pressure in the cylinders. It is, therefore, best not to split up the jet by using a bridge in cases where the draft is unsatisfactory, as the desired results may be obtained by reducing the diameter of the exhaust nozzle.

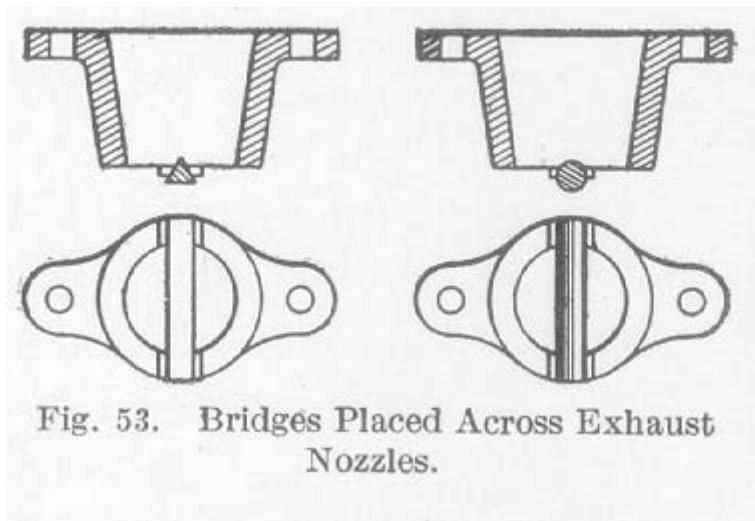
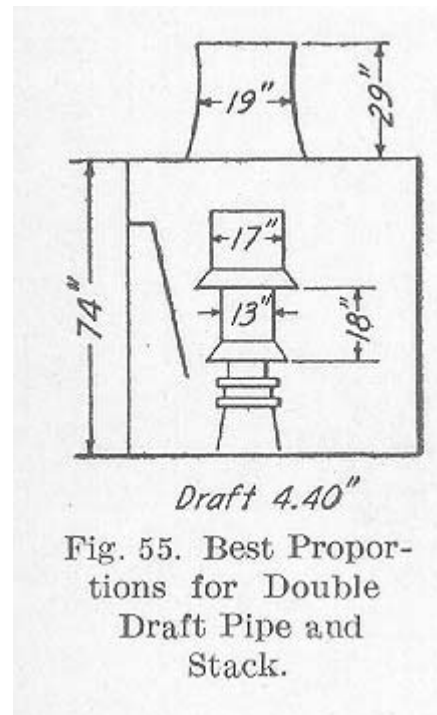
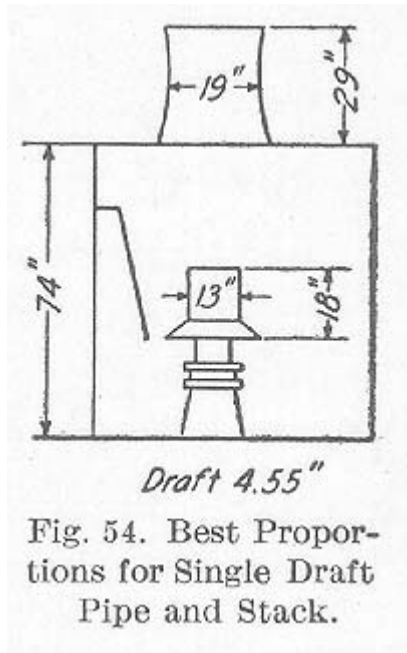

Fig. 53. Bridges Placed Across Exhaust Nozzles.

As previously stated, draft or petticoat pipes are used for the purpose of increasing the draft or vacuum in the front end and in the tubes. A great many tests have been made under the supervision of the Master Mechanics' Association to determine the proper proportions of the petticoat pipes and their best relative position with reference to the stack and exhaust nozzle.

The report of the committee of the Master Mechanics' Association with reference to single draft pipes states "that for the best results, the presence of a draft pipe requires a smaller stack than would be used without it but that no best combination of single draft pipe and stack could be found which gave a better draft than could be obtained by the use of a properly proportioned stack without the draft pipe. While the presence of a draft pipe will improve the draft when the stack is small it will not do so when the stack is sufficiently large to serve without it. The best proportion and adjustment of a single draft pipe and stack are shown in [Fig. 54.](#)"



The finding of the same committee with reference to the use of the double draft pipes is as follows: "Double draft pipes of various diameters and lengths and having many different positions within the front ends all in combination with stacks of different diameters, were included in the experiments with results which justify a conclusion similar to that reached with reference to single draft pipes. Double draft pipes make a small stack workable. They cannot serve to give a draft equal to that which may be obtained without them provided the plain stack is suitably proportioned. The arrangements and proportions giving the best results are illustrated in [Fig. 55.](#)"

**Stack.** The stack is one of the most important features of the front end. Many different forms and proportions of stacks have been employed but at the present time only two

general types are found in use to any great extent, namely, the *straight* and *tapered stacks*.

In connection with tests conducted in the Locomotive Testing Laboratory at Purdue University, it has been found that the tapered stack gives much better draft values than the straight stack. It was also found that the effect on the draft due to minor changes of proportion, both of the stack itself and the surrounding mechanism, was least noticeable when the tapered stack was used than was the case with the straight stack. A variation of one or two inches in the diameter of the tapered stack or height of the exhaust nozzle affected the draft less than similar changes with a straight stack. For these reasons, the

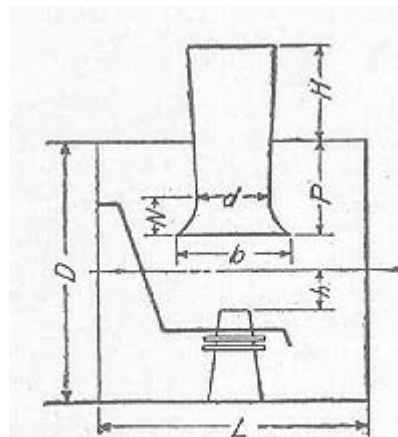

Fig. 56. Arrangement of Nozzle and Stack.

tapered stack was recommended in preference to the straight stack. By the term *tapered stack* as herein referred to, is meant a stack having its least diameter or choke 16½ inches from the bottom, and a diameter above this point increasing at the rate of two inches for each additional foot.

The diameter of any stack designed for best results is affected by the height of the exhaust nozzle. As the nozzle is raised, the diameter of the stack must be reduced and as the nozzle is lowered, the diameter of the stack must be increased. From the facts mentioned above, it can be seen there exists a close relation between the exhaust nozzle, petticoat pipe, stack, and the diaphragm; hence a standard front end arrangement has been recommended and is presented herewith.

The best arrangement of front end apparatus is shown in [Fig. 56](#), in which

- $H$  = height of stack above boiler shell in inches
- $D$  = diameter of shell in inches
- $L$  = length of the front end in inches
- $P$  = the distance in inches stack extends into the smoke-box
- $N$  = distance in inches from base of stack to choke
- $b$  = width of stack in inches at the base
- $d$  = diameter of stack in inches at the choke
- $h$  = distance in inches of the nozzle below the center line of smoke-box

In order to obtain the best results,  $H$  and  $h$  should be made as great as possible while the other principal dimensions should be as follows:

$$d = .21 D + .16 h$$

$$b = 2 d \text{ or } .5 D$$

$$P = .32 D$$

$$N = .22 D$$

**Rate of Combustion.** It is a well-known fact that each pound of fuel is capable of giving out a certain definite amount of heat. Therefore, the more rapid the combustion, the greater the amount of heat produced in a given time. In stationary boilers, where the grate is practically unlimited, the rate of combustion per square foot of grate area per hour



varies from 15 to 25 pounds. In locomotives, however, where the grate area is limited, the fuel consumption is much greater, rising at times as high as 200 pounds per square foot of grate area per hour. This rapid combustion results in a great loss of heat and a reduction in the amount of water evaporated per pound of coal. It has been shown that when coal is burned at the rate of 50 pounds per square foot of grate area per hour, 8¼ pounds of water maybe evaporated for each pound of coal. While if the rate of combustion is increased to 180 pounds per square foot of grate area per hour, the evaporation will fall off to about five pounds, a loss of water evaporated per pound of coal of nearly 40 per cent. This loss may be due to a failure of the heating surface to absorb properly the increased volume of heat passing over them, or to the imperfect combustion of the fuel on the grate, or it may be due to a combination of these causes.

The results of experiments show that the lower the rate of combustion the higher will be the efficiency of the furnace, the conclusion being that very high rates of combustion are not desirable and consequently that the grate of a locomotive should be made as large as possible so that exceptionally high rates of combustion will not be necessary.

With high rates of combustion, the loss by sparks is very serious and may equal in value all of the losses occurring at the grate. [Fig. 57](#) is a diagram representing the losses that

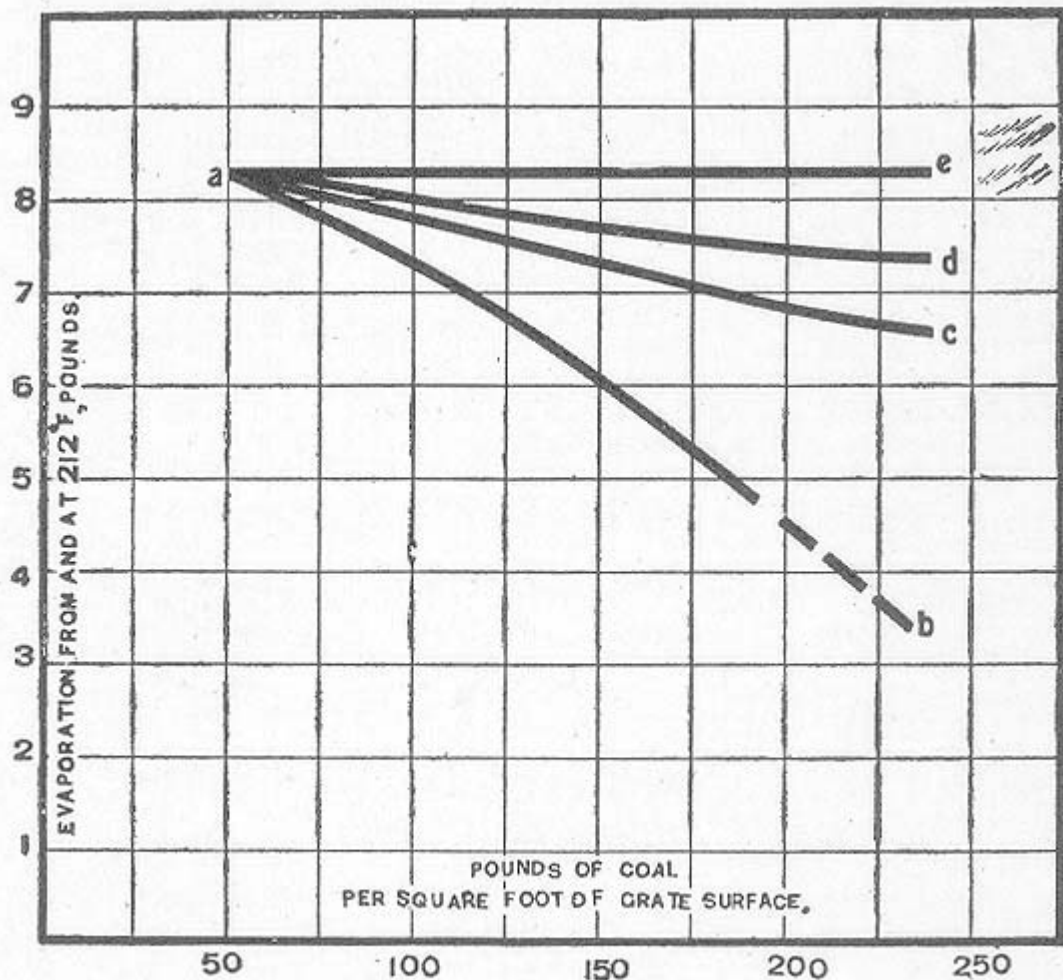

Fig. 57. Curves Showing Losses Due to Increases in Rate of Combustion.

occur, due to an increase in the rate of combustion. The line *a b* illustrates graphically the amount of water evaporated per pound of coal for the various rates of combustion. Thus, with a rate of 50 pounds per square foot of grate area per hour,  $8\frac{1}{4}$  pounds of water are evaporated. When the rate of combustion is raised to 175 pounds, only about  $5\frac{1}{3}$  pounds of water are evaporated. It is thus seen that the efficiency of the locomotive from the standpoint of water evaporated per pound of coal decreases as the rate of combustion per square foot of grate area increases. If it could be assumed that the heat developed in the furnace would be absorbed with the same degree of completeness for all rates of combustion, the evaporation would rise to the line *a c*. If, in addition to this, it could be assumed that there were no spark losses, the evaporation would rise to the line *a d*. Finally, if in addition to these, it could be assumed that there were no losses by the excess admission of air or by incomplete combustion, then the evaporation would remain constant for all rates of combustion and would be represented by the line *a e*. That is, with the boiler under normal conditions, the area *a b c* represents the loss occasioned by deficient heating surface; the area *a c d* represents that caused by spark losses; and the area *a d e* represents that due to excessive amounts of air and by imperfect combustion.

**Spark Losses.** From the diagram shown in [Fig. 57](#), it is evident that one of the principal heat losses is that of sparks. By the term *sparks* is meant the small particles of partially burned coal which are drawn through the flues and ejected through the stack by the action of the exhaust. In the operation of a locomotive, it has been demonstrated that the weight of sparks or cinders increases with the rate of combustion and may reach a value of from 10 to 15 per cent of the total weight of coal fired. Damage suits frequently arise, due to fires started by cinders thrown from the stack of the locomotive. Experiments have shown, however, that sparks from a locomotive will not be likely to start fires beyond the right of way.

**High Steam Pressures.** With the development of high-power locomotives came the use of high steam pressures. At first, only very low pressures were carried but soon 200 pounds pressure per square inch became very common and 220 and 225 not unusual. But with the increase of pressure there came an increase in trouble due to bad water, leaky flues, and an increase in incidental leaks in the boiler. All of these factors affected the performance of the locomotive. To determine to what extent the economic performance of the boiler was affected by an increase of steam pressure and also the most economical steam pressure to use, a series of tests were carried out at Purdue University. The following are the conclusive results as read before the Western Railway Club by Dean W. F. M. Goss:

#### **THE EFFECT OF DIFFERENT PRESSURES UPON BOILER PERFORMANCE**

1. The evaporative efficiency of a locomotive boiler is but slightly affected by changes in pressure between the limits of 120 pounds and 240 pounds.
2. Changes in steam pressure between the limits of 120 pounds and 240 pounds will produce an effect upon the efficiency of the boiler which will be less than one-half pound of water per pound of coal.
3. It is safe to conclude that changes of no more than 40 or 50 pounds in pressure will produce no measurable effect upon the evaporative efficiency of the modern locomotive boiler.

## THE EFFECT OF DIFFERENT PRESSURES UPON SMOKE-BOX TEMPERATURES

1. The smoke-box temperature falls between the limits of 590 degrees F. and 860 degrees F., the lower limit agreeing with the rate of evaporation of 4 pounds per foot of heating surface per hour and the higher with a rate of evaporation of 14 pounds per square foot of heating surface per hour.
2. The smoke-box temperature is so slightly affected by changes in steam pressure as to make negligible the influence of such changes in pressure for all ordinary ranges.

### CONCLUSIONS

1. The steam consumption under normal conditions of running has been established as follows:

BOILER PRESSURE.....STEAM per HORSEPOWER HOUR

120.....29.1

140.....27.7

160.....26.6

180.....26.0

200.....25.5

220.....25.1

240.....24.7

2. The results show that the higher the pressure, the smaller the possible gain resulting from a given increment of pressure. An increase of pressure from 160 to 200 pounds results in a saving of 1.1 pounds of steam per horse-power per hour while a similar change from 200 pounds to 240 pounds improves the performance only to the extent of .8 of a pound per horse-power hour.
3. The coal consumption under normal conditions of running has been established as follows:

BOILER PRESSURE.....COAL per HORSEPOWER HOUR

120.....3.84

140.....3.67

160.....3.53

180.....3.46



200.....	3.40
220.....	3.35
240.....	3.31

4. An increase of pressure from 160 to 200 pounds results in a saving of 0.13 pounds of coal per horse-power hour while a similar change from 200 to 240 results in a saving of but 0.09 pounds.
5. Under service conditions, the improvement in performance with increase of pressure will depend upon the degree of perfection attending the maintenance of the locomotive. The values quoted in the preceding paragraphs assume a high order of maintenance. If this is lacking, it may easily happen that the saving which is anticipated through the adoption of higher pressures will entirely disappear.
6. The difficulties to be met in the maintenance both of boiler and cylinders increase with increase of pressure.
7. The results supply an accurate measure by which to determine the advantage of increasing the capacity of a boiler. For the development of a given power, any increase in boiler capacity brings its return in improved performance without adding to the cost of maintenance or opening any new avenues for incidental losses. As a means of improvement it is more certain than that which is offered by increase of pressure.
8. As the scale of pressure is ascended an opportunity to further increase the weight of a locomotive should in many cases find expression in the design of a boiler of increased capacity rather than in one of higher pressures.
9. Assuming 180 pounds pressure to have been accepted as standard and assuming the maintenance to be of the highest order, it will be found good practice to utilize any allowable increase in weight by providing a larger boiler rather than by providing a stronger boiler to permit higher pressures.
10. Whenever the maintenance is not of the highest order, the standard running pressures should be below 180 pounds.
11. Where the water which must be used in boilers contains foaming or scale-making admixtures, best results are likely to be secured by fixing the pressure below the limit of 180 pounds.
12. A simple locomotive using saturated steam will render good and efficient service when the running pressure is as low as 160 pounds. Under most favorable conditions, no argument is to be found in the economical performance of a machine which can justify the use of pressures greater than 200 pounds.

**Heating Surface.** While the points thus far considered are more or less important in their bearing in the generation of steam, yet the amount of heating surface is, as a rule, the most important. As previously stated, the lower the rate of combustion per square foot of heating surface, the higher will be the rate of evaporation per pound of coal. The ratio of the heating surface of the flues to that of the fire-box varies greatly, in some cases being only 9 to 1 while in others it is found as great as 18 to 1. There is perhaps a correct value for this ratio, but at the present time it is unknown. The relation existing between the total heating surface and the grate area varies between wide limits for different cases. Table III, taken from the Proceedings of the Master Mechanics' Association for 1902, gives the

ratio of heating surface to grate area in passenger and freight locomotives burning various kinds of fuel.

**TABLE III**

**Ratio of Heating Surface to Grate Area**

<b>Fuel</b>	<b>Passenger Locomotive Simple</b>	<b>Passenger Locomotive Compound</b>	<b>Freight Locomotive Simple</b>	<b>Freight Locomotive Compound</b>
Free Burning Bituminous	65 to 90	75 to 95	70 to 85	65 to 85
Average Bituminous	50 to 65	60 to 75	45 to 70	50 to 65
Slow Burning Bituminous	40 to 50	35 to 60	35 to 45	45 to 50
Bituminous, Slack, and Free Burning Anthracite	35 to 40	30 to 35	30 to 35	40 to 45
Low Grade Bituminous, Lignite, and Slack	28 to 35	24 to 30	25 to 30	30 to 40

From the foregoing, it is evident that it is exceedingly difficult to determine just how much heating surface a locomotive boiler should have to give the best results. As a rule, they are made as large as possible so long as the total allowable weight of the locomotive is not exceeded. This is not, however, a scientific rule to follow but it is safe to say that the value of no locomotive has ever been impaired by having too much heating surface. The greater the boiler power, the higher will be the speed which can be maintained. It is important that the boiler be covered with a good lagging in order to prevent loss of heat due to radiation.

**Superheaters.** When steam is admitted to the cylinder it meets the cylinder walls, the temperature of which is less than that of the entering steam, and there results an interchange of heat. The fact that the steam gives up a part of its heat to the cylinder, causes some of the steam to condense. As the piston proceeds on its stroke and expansion occurs, some of the steam initially condensed will be re-evaporated. The cylinder, therefore, goes through a process of alternately cooling and reheating, resulting in condensation and re-evaporation; this is the principal loss occurring in the process.

In order to assist in reducing this loss to a minimum, superheated steam is being used on locomotives, to a certain limited extent in the United States, by the addition of a superheater. A superheater consists of a series of tubes and headers usually placed in the smoke-box, through which steam passes on its way to the cylinders, thus raising its temperature. It has now secured a certain amount of heat energy from the waste gases which pass out of the stack, thus improving the economy of the locomotive.

*Pielock Superheater.* The Pielock superheater, illustrations of which are shown in [Fig. 58](#) and [Fig. 59](#), is found in use on a number of railways in Germany and in Italy, and also on the Hungarian State Railways. Its construction consists of a box containing tube plates corresponding to those of the boiler, the box being set in the boiler barrel so that the flues pass through it. It is placed at such a distance from the fire-box as will prevent the tubes

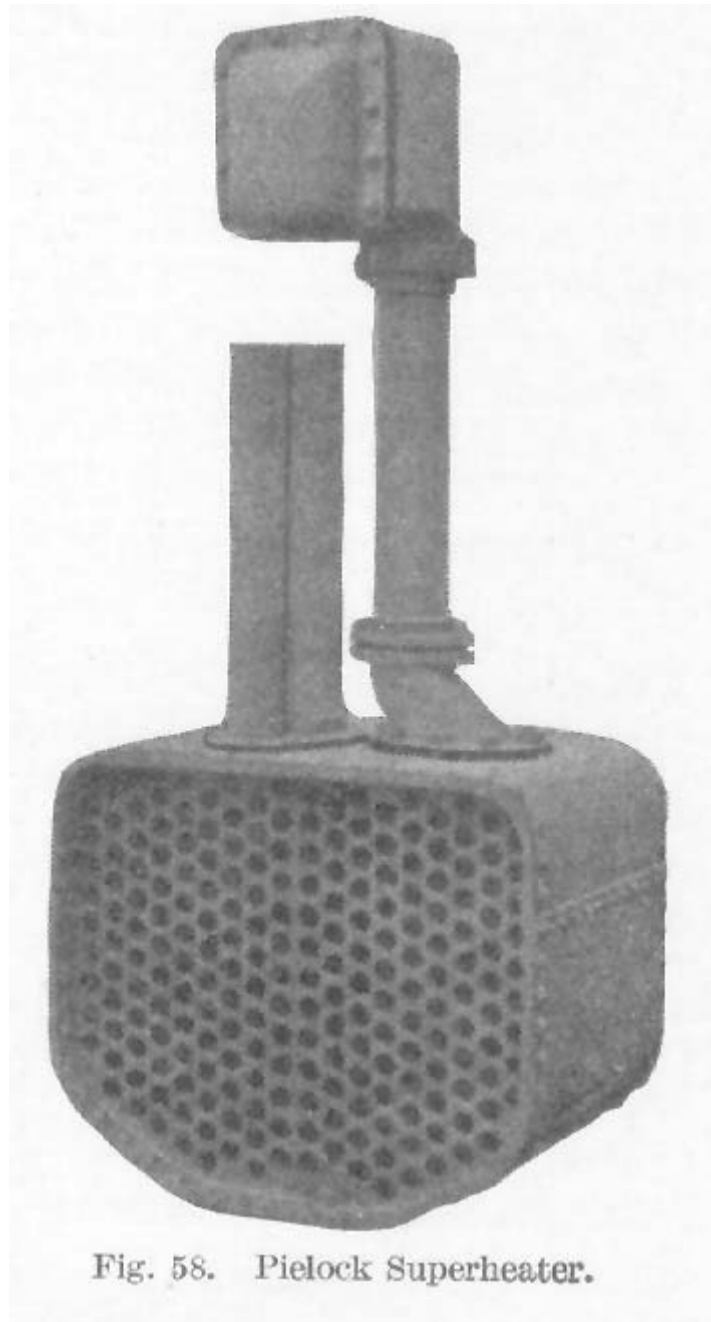

Fig. 58. Pielock Superheater.

from becoming overheated. The vertical baffle plates *G* between the rows of tubes cause the steam to follow a circuitous path passing up and down between the tubes. The steam from the dome passes down the open pipe *A*, [Fig. 59](#), to the left-hand chamber *B*, then transversely to the several chambers as shown by arrows until it reaches the right-hand chamber *C*. From the chamber *C* it passes up through the pipe *D* to the chamber enclosing a throttle valve from which it enters the steam pipe *E*.

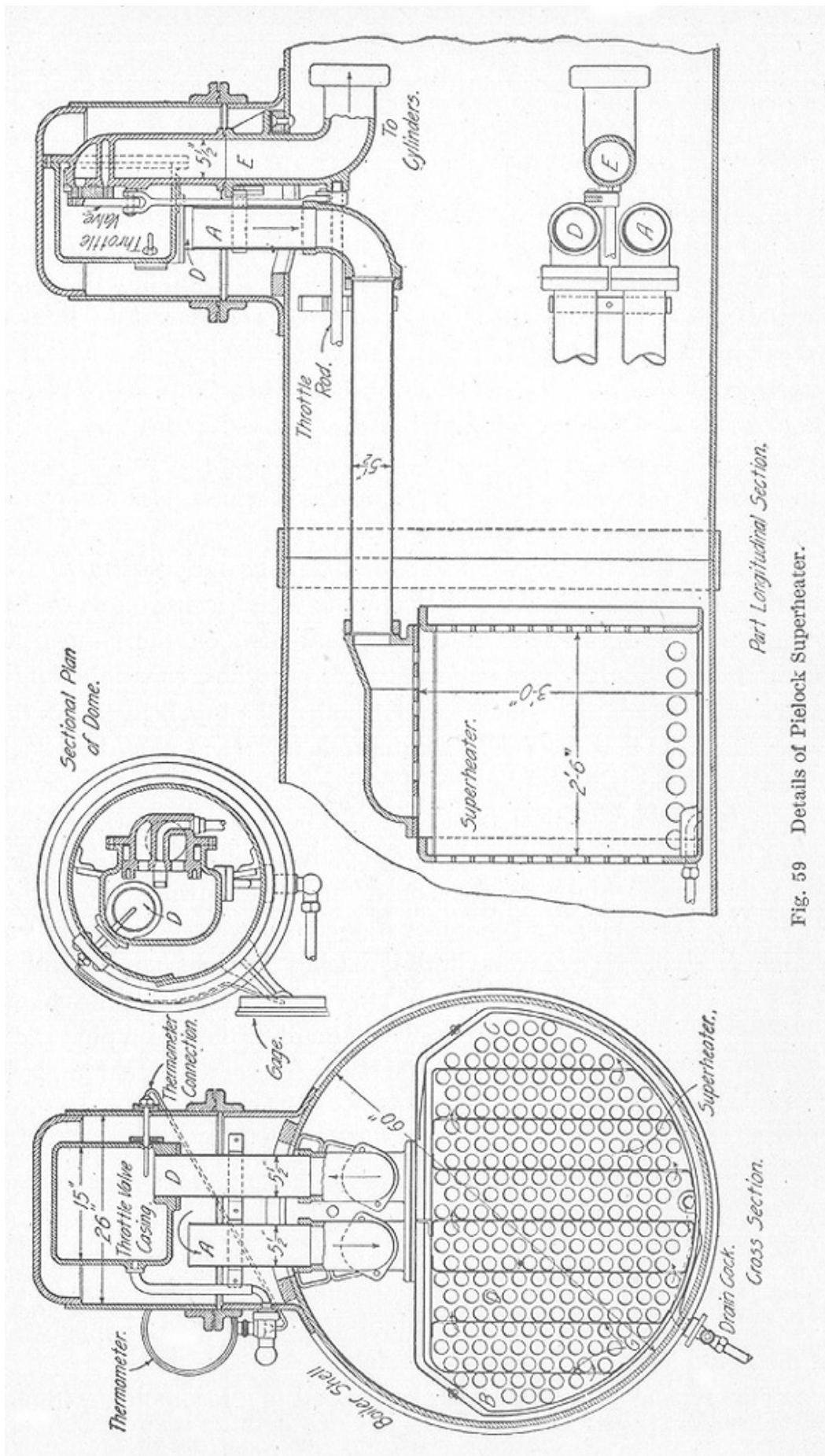

Fig. 59 Details of Piolock Superheater.

In installing the superheater, the boiler tubes are first set in place in the superheater and then placed in the boiler, the smoke-box tube plate being left off for this purpose. The tubes are first expanded into the fire-box or back flue-sheet, then in the superheater plates (for which a special mandrel is used), and finally in the front flue-sheet. A blow-off cock extends from the bottom of the superheater through the boiler by means of which any leaks in the superheater may be detected. A gauge at the bottom indicates the degree of superheat of the steam in the throttle valve chamber.

This type of superheater can be applied to a locomotive without making any alteration since the superheater is built to fit the boiler in which it is to be used. It does not interfere with the cleaning of the flues or the washing out of the boiler. It is reported that by the use of this superheater a saving in coal of about 15 to 18 per cent and in water of about 20 per cent, is effected.

*Schmidt Superheater.* The Schmidt superheater is another type which is largely used on German railroads. Its construction is based on entirely different principles from those of the Pielock superheater. It differs from the Schenectady or Cole superheater in details only.

*Schenectady or Cole Superheater.* The Schenectady superheater was developed by the American Locomotive Company. It has had a large application in recent years and good results are being obtained. The general arrangement and construction of this superheater is shown in [Fig. 60](#) and [Fig. 61](#).

The use of bent tubes and the necessity for dismantling the whole apparatus in order to repair a single leaky boiler tube gave rise to many objections to the use of superheaters. In the construction of the Schenectady superheater, many of the objectionable features have been eliminated. By reference to [Fig. 60](#), it will be seen that steam entering the T-pipe from the dry pipe *A* is admitted to the upper compartment only. To the front side of the T-pipe are attached a number of header castings *B*, the joint being made with copper wire gaskets, as in steam chest practice. Each header casting is subdivided into two compartments by a vertical partition shown in cross-section at *C*. Five tubes each 1 1/16 inch outside diameter are inserted through holes (subsequently closed by plugs) in the front wall of each header casting. These tubes having first been expanded, special plugs are firmly screwed into the vertical partition wall and are enclosed by five 1 3/4-inch tubes which are expanded into the rear wall of the header casting in the usual way. Each nest of two tubes is encased by a regular 3-inch boiler tube which is expanded into the front and back tube sheets as usual. The back end of each inner tube is left open and the back end of each middle tube is closed. The back ends of the two tubes are located about 36 inches forward from the rear flue sheet. The arrangement of the three flues is shown in [Fig. 61](#). The inner tube is allowed to drop and rest on the bottom of the middle tube while the end of the middle tube is so constructed as to support both the inner and middle tubes in the upper part of the 3-inch tube, thus leaving a clear space below.

As can be seen from [Fig. 60](#), steam from the dry pipe enters the forward compartments of each of the header castings, passes back through each of the inner tubes, thence forward through the annular space between the inner and middle tubes, through the rear compartments of each of the header castings, and thence into the lower compartment of the T-pipe, thence by the right and left steam pipe *D* and *E* to the cylinders. The steam in passing through the different channels is superheated by the smoke-box gases and

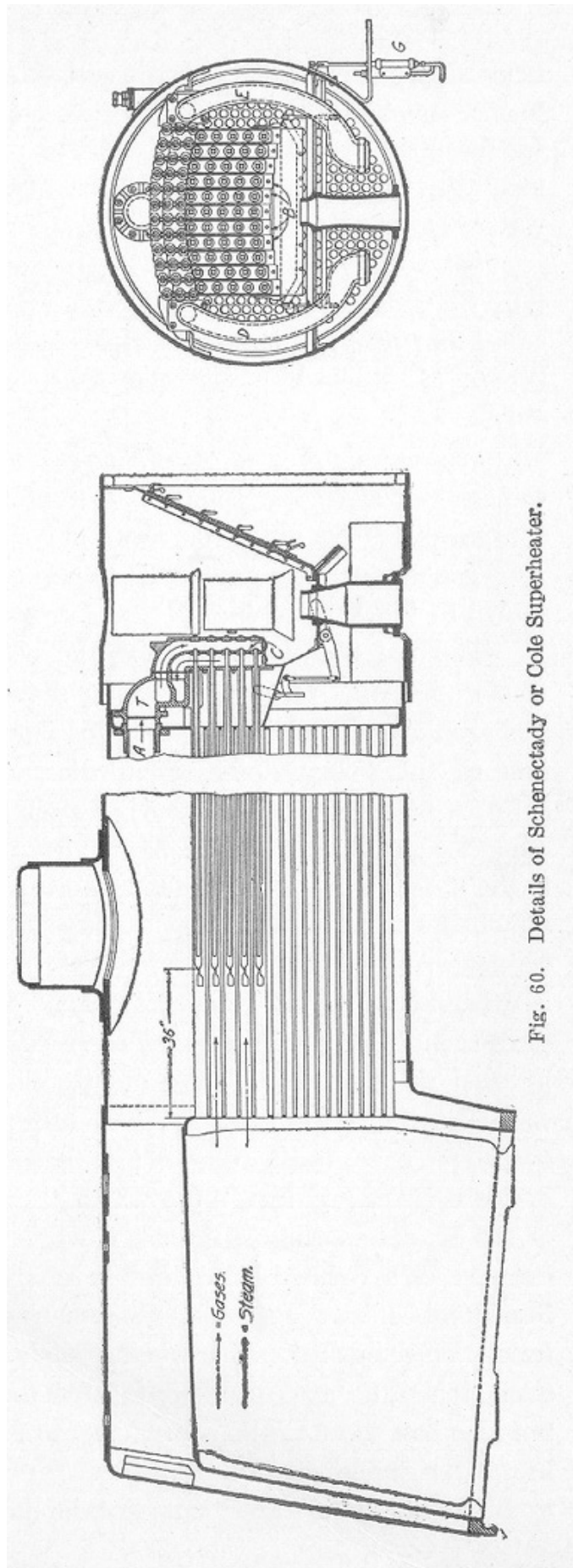

Fig. 60. Details of Schenectady or Cole Superheater.



products of combustion. In this particular design, fifty-five 3-inch tubes are employed, thus displacing as many of the regular smaller tubes as would occupy a similar space.

It is necessary to provide some means by which the superheater tubes shall be protected from excessive heat when steam is not being passed through them. In this instance, this is accomplished by the automatic damper shown in [Fig. 60](#). The entire portion of the smoke-box below the T-pipe and back of the header castings is completely enclosed by metal plates. The lower part of this enclosed box is provided with a damper which is automatic in its action. Whenever the throttle is opened and steam is admitted to the steam chest, the piston of the automatic damper cylinder *G* is forced upward and the damper is held open, but when the throttle is closed, the spring immediately back of the automatic damper cylinder closes the damper and no heat can be drawn through the 3-inch tubes. In this way, the superheater tubes are prevented from being burned. There is a slight loss of heating surface in introducing the group of 3-inch tubes and applying a superheater, but this loss is more than offset by the gain in economy due to the use of the superheated steam.

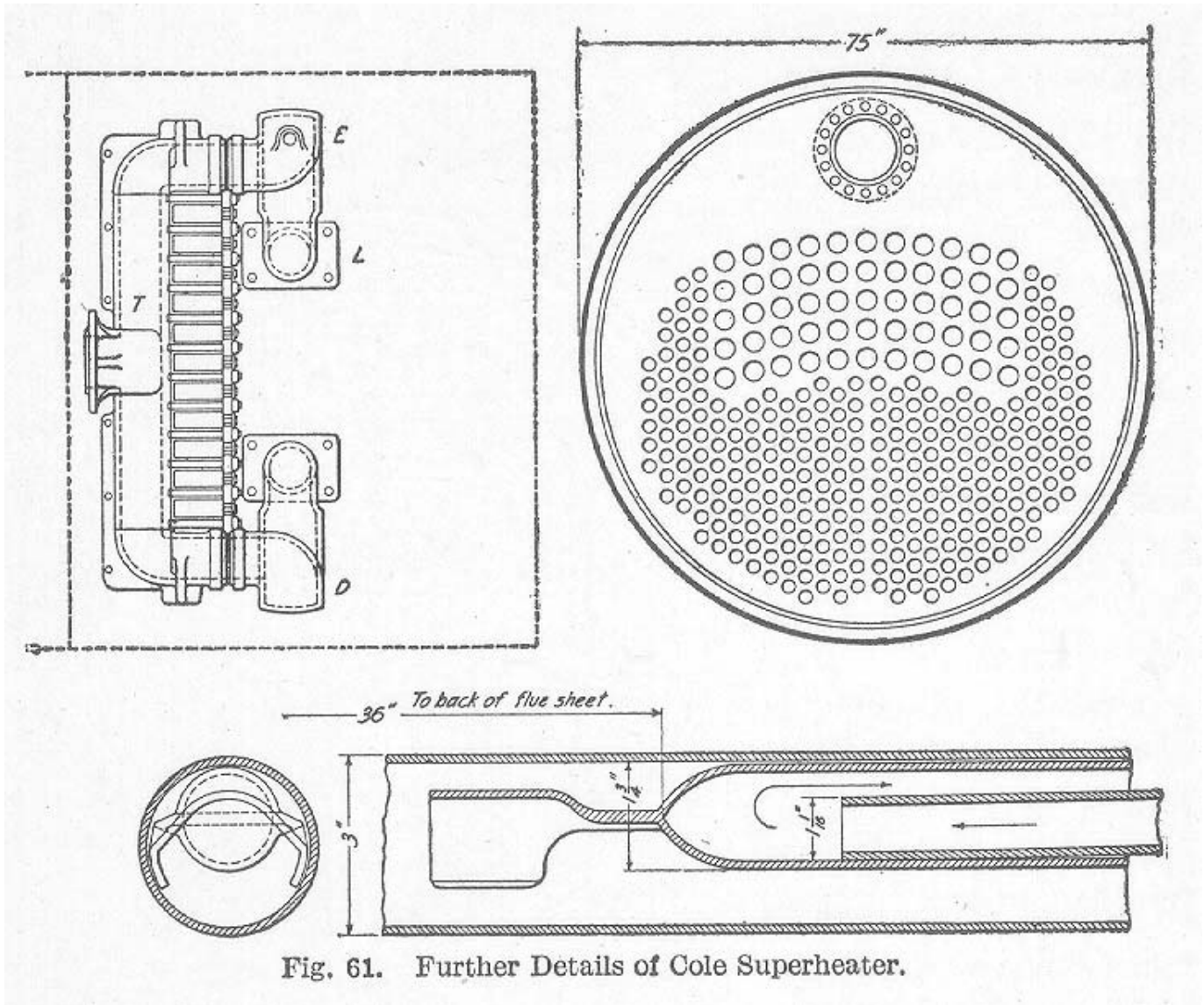

Fig. 61. Further Details of Cole Superheater.

The results of laboratory tests of the Schenectady superheater indicate a saving of from 14 to 20 per cent of water and from 5 to 12 per cent of coal.

*Baldwin Superheater.* The Baldwin superheater which is now being used by some railroads differs from the Schenectady and the Pielock superheaters in that it is found entirely within the smoke-box. It can be applied to any locomotive without disturbing the boiler and its application does not reduce the original heating surface.

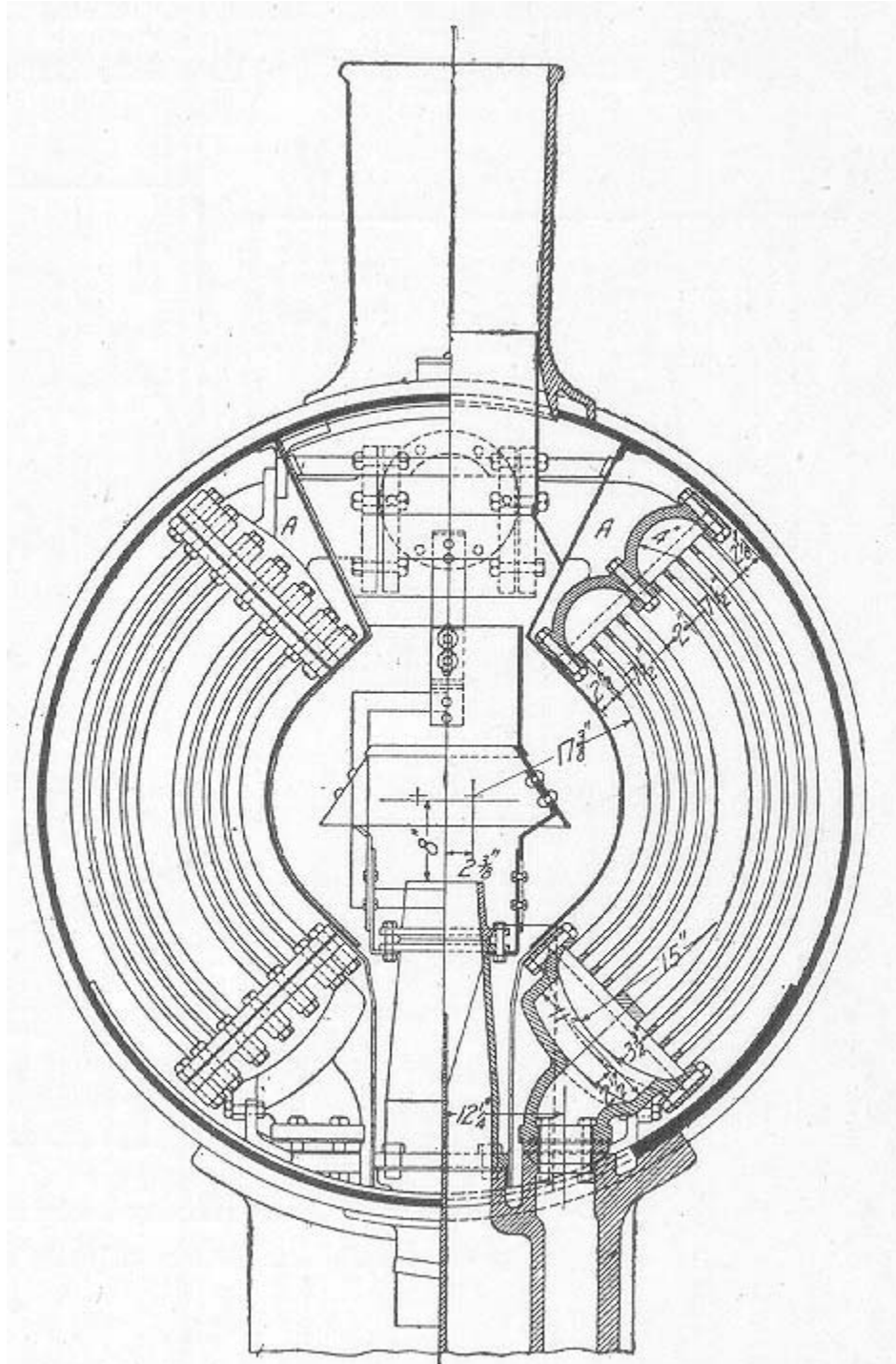

Fig. 62. Baldwin Superheater.

It consists of two cast-steel headers *A*, [Fig. 62](#), which are cored with proper passages and walls. These headers are connected by a large number of curved tubes which follow the contour of the smoke-box shell, and are expanded in tube plates bolted to the headers.

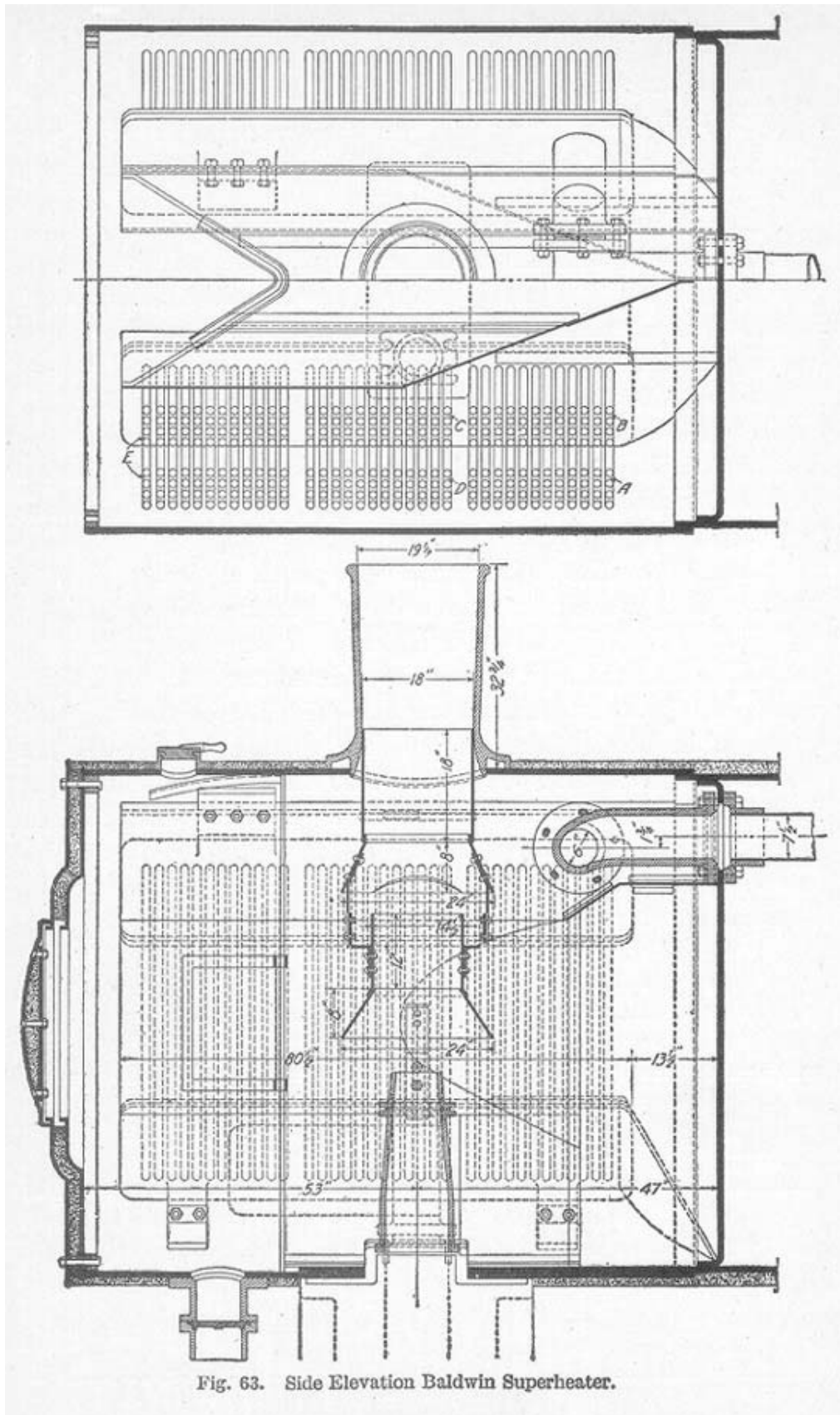

Fig. 63. Side Elevation Baldwin Superheater.

The curved tubes are divided into groups, the passages in the headers being so arranged that the steam after leaving the T-head on either side passes down through the group forming the outer four rows of the rear section of superheater tubes, then crosses over in the lower header and passes up through the inner group of the next section and up through the outer group and thence down through both the inner and outer groups of the forward section and through a passage-way in the lower header to the saddle. As illustrated in [Fig. 63](#), these tubes are heated by the gases from the fire tubes and the deflecting plates are so arranged as to compel these gases to circulate around the tubes on both sides to the front end of the smoke-box and thence back through the center to the stack. Thus, the superheater uses only such heat as is ordinarily wasted through the stack, and whatever gain in superheat is obtained, is clear gain.

Experiments so far made with this type of superheater show that while it is not possible to obtain a very high degree of superheat, yet enough is obtained to very decidedly increase the economy of the boiler. The front end is heavily lagged at all points to prevent as far as possible all loss of heat by radiation.

There have been several types of superheaters placed on the market in addition to those already mentioned, all having more or less merit. They differ in detail of construction but the principle embodied is covered by some one of the types described in the preceding pages.

*Superheater Tests.* Of recent years much experimental work has been done to ascertain the relative increase in economy obtained by the use of locomotives equipped with superheaters and to determine the increase, if any, in the maintenance of locomotives so equipped. In many instances the published data on the subject is presented in such a manner as to make comparisons rather difficult. The experiments conducted by Dr. Goss during the last few years have been of much interest to railroad men. The work was conducted on the Purdue locomotive, having a boiler designed to carry a working pressure of 250 pounds per square inch. The results obtained are very briefly summarized in Tables IV, V, VI, and VII.

**TABLE IV**  
**Steam per Indicated Horsepower per Hour**  
(Cole Superheater)

<b>Boiler Pressure in Pounds per Sq. In. Gage</b>	<b>Superheat in Degrees F.</b>	<b>Pounds Steam per I.H.P. per Hour Saturated Steam</b>	<b>Pounds Steam per I.H.P. per Hour Superheated Steam</b>	<b>Saving in Per Cent by Use of Superheated Steam</b>
240	139.6	24.7	22.6	8.50
220	145.0	25.1	21.8	13.14
200	150.3	25.5	21.6	14.51
180	155.6	26.0	21.9	15.77
160	160.8	26.6	22.3	16.16
140	166.1	27.7	22.9	17.32
120	171.4	29.1	23.8	18.21



**TABLE V****Coal per Indicated Horsepower per Hour**

(Cole Superheater)

<b>Boiler Pressure in Pounds per Sq. In. Gage</b>	<b>Pounds Dry Coal per I.H.P. per Hour Saturated Steam</b>	<b>Pounds Steam per I.H.P. per Hour Superheated Steam</b>	<b>Saving in Per Cent by Use of Superheated Steam</b>
240	3.31	3.12	5.74
220	3.37	3.00	10.98
200	3.43	2.97	13.41
180	3.50	3.01	14.00
160	3.59	3.08	14.21
140	3.77	3.17	19.51
120	4.00	3.31	17.27

**TABLE VI****Steam per Indicated Horsepower per Hour**

(Schmidt Superheater)

<b>Boiler Pressure in Pounds per Sq. In. Gage</b>	<b>Superheat in Degrees F.</b>	<b>Pounds Steam per I.H.P. per Hour Saturated Steam</b>	<b>Pounds Steam per I.H.P. per Hour Superheated Steam</b>	<b>Saving in Per Cent by Use of Superheated Steam</b>
240	222.2*	24.7	19.5*	21.05
220	226.5*	25.1	19.0*	24.30
200	230.8	25.5	18.9	25.89
180	235.1	26.0	18.7	28.08
160	239.4	26.6	18.9	28.94
140	243.8	27.7	19.5	29.60
120	248.6	29.1	21.0	27.83

\*Results estimated for making comparisons.

**TABLE VII****Coal per Indicated Horsepower per Hour**

(Schmidt Superheater)

<b>Boiler Pressure in Pounds per Sq. In. Gage</b>	<b>Pounds Dry Coal per I.H.P. per Hour Saturated Steam</b>	<b>Pounds Steam per I.H.P. per Hour Superheated Steam</b>	<b>Saving in Per Cent by Use of Superheated Steam</b>
240	3.31	2.63*	20.54
220	3.37	2.57*	23.74
200	3.43	2.55	25.65
180	3.50	2.51	28.28
160	3.59	2.55	28.97
140	3.77	2.63	30.24
120	4.00	2.89	27.75

\*Results estimated for making comparisons.

The results presented in Tables IV to VII were all obtained at a uniform speed of 30 miles per hour, and may be briefly stated as follows:

(a) With the locomotive equipped with a Cole superheater a saving was effected, over values obtained with saturated steam, in steam used per I.H.P. per hour of from 8.5 to 18.21 per cent and in coal per I.H.P. per hour of from 5.74 to 17.25 per cent.

(b) With the locomotive equipped with a Schmidt superheater the saving of steam used per I.H.P. per hour varied from 21.05 to 29.60 per cent, while the saving in coal used per I.H.P. per hour varied from 20.54 to 30.24 per cent.

(c) The superheat in the branch pipe just before entering the cylinders, varied from 139.7 to 171.4 degrees F., when the Cole superheater was used, and from 222.2 to 248.6 degrees F., when the Schmidt superheater was used,

The higher efficiency obtained of the Schmidt superheater over the Cole superheater is partially accounted for by the fact that the total heating surface of the Schmidt amounted to 325 square feet, while that of the Cole was only 193 square feet.

In conclusion, it may be stated that the superheating simple locomotive will reduce the steam and coal consumption to that required by the compound locomotive. It will operate efficiently on comparatively low steam pressures, and its maximum possible power is considerably beyond that of the simple locomotive using saturated steam. Many complaints have been made by operators relative to difficulty experienced in securing proper lubrication of the valve, etc., when using superheated steam. It has been demonstrated, however, that this difficulty can be overcome by the exercise of good judgment in the use of and proper amount and grade of lubricating oil.

**Locomotive Boiler Design.** The design of locomotive boilers and engines is a very deep subject-one requiring much thought and study. Limited space prevents going into a discussion of the reasons for the adoption of different designs. The following formulae



for the calculation of thickness of plates, spacing of rivets, etc., are given. Some of these formulae, while being semi-empirical, are based on theoretical assumptions and represent modern practice in the design of parts mentioned. In figuring the thickness of the boiler shell, the following formula is given:

$$t = \frac{P D f}{2 T E}$$

where

$t$  = thickness of shell in inches

$P$  = steam pressure, pounds per square inch

$D$  = inside diameter of shell in inches

$f$  = factor of safety, usually taken not less than  $4\frac{1}{2}$

$T$  = tensional strength of plate in pounds per square inch, usually taken as 55,000

$E$  = efficiency of longitudinal joint expressed as a decimal fraction which may be taken as .85

*Example.* In a given locomotive boiler, the first ring is 60 inches in diameter; the steam pressure is 200 pounds. Required the thickness of the plate.

SOLUTION.

$$\begin{aligned} t &= \frac{200 \times 60 \times 4.5}{2 \times 55000 \times .85} \\ &= .57 \text{ inches} \end{aligned}$$

The efficiency of the joint is expressed as follows:

$$E = \frac{\text{Tearing resistance of joint}}{\text{Tearing resistance of solid plate of same dimensions}}$$

or

$$E = \frac{\text{Shearing resistance of joint}}{\text{Shearing resistance of solid plate of same dimensions}}$$

NOTE: Use whichever value is the least.

In computing the thickness of the conical connection in a boiler shell use the formula

$$t = \frac{P D f}{2 T E}$$

the inside diameter at the large end being considered.

In calculating the thickness of the fire-box side and fire-door sheets, the following formula may be used:

$$t = \sqrt{\frac{2 a^2 P}{49500}}$$

where  $a$  = the pitch of stay-bolts in inches.

The pitch of the stay-bolts may be taken as

$$a = \sqrt{\frac{49500 t^2}{2 P}}$$

*Example.* Determine the thickness of the side sheets when the steam pressure employed is 200 pounds per square inch and the stay-bolts are spaced 4 inches from center to center.

SOLUTION.

$$t = \sqrt{\frac{2 \times 4^2 \times 200}{49500}}$$
$$= .36 \text{ inches}$$

The safe tensile strength of stay-bolts should be taken not to exceed 5,500 pounds per square inch.

The diameter of rivets may be determined by the following formula:

$$d = 1.2 \sqrt{t}$$

The following standard thicknesses of plates are used in locomotive boiler construction: Crown sheet, side sheet, and back fire-box sheet, 3/8 inch in thickness; for boiler pressures not exceeding 200 pounds, the boiler head, roof, sides, and dome, 1/2 inch thick, while for boilers with steam pressures between 200 and 240 pounds, these plates are 9/16 inch thick.

In designing the riveted joints, their strength must be considered from several different standpoints. It must be sufficiently strong to withstand the tensional stress on the metal contained in the plate between the rivets. The plates must be of such thickness as will safely carry the compressional stresses behind the rivets and the rivets must be placed in rows sufficiently far apart and far enough from the edge of the plate to insure against shearing or tearing out of the metal. In the formulae for the design of a riveted joint, the following notation will be used:

$d$  = diameter of rivet hole in inches

$p$  = pitch or distance in inches between center to center of rivets

$t$  = thickness of plate in inches

$h$  = distance in inches from edge of plate to center of first rivet hole

$T$  = tensile strength of plate in pounds per square inch, usually taken as 55,000

$S$  = shearing strength of rivets in pounds per square inch, usually taken as 55,000

$R$  = shearing strength of plate in pounds per square inch, usually taken as 45,000 pounds per square inch

$C$  = crushing strength of plate in pounds per square inch, usually taken as 50,000 pounds per square inch

$f$  = factor of safety usually taken not less than 4-1/2

The safe resistance in pounds per square inch offered by one rivet to shear

$$= .7854 d^2 \frac{S}{f}$$

The safe resistance in pounds per square inch offered to tearing of plate between rivet holes

$$= (p-d) t \frac{T}{f}$$

The safe resistance to crushing in pounds per square inch of the portion of the plate in front of rivet

$$= \frac{t d C}{f}$$

The safe resistance to shearing out in pounds per square inch of that portion of the plate in front of the rivet

$$= \frac{2 h t R}{f}$$

**Boiler Capacity. Importance.** In the early days of the locomotive very little attention was given to the size of the boiler. If the cylinders were large enough to pull a train of reasonable size up the maximum grade and the driving wheels were loaded sufficiently to prevent slipping, the results secured were generally considered satisfactory. Today, however, conditions are changed. Now the capacity of the locomotive boiler for the generation of steam is looked upon as the most important feature in connection with the design of a locomotive and, as a rule, the boiler is made as large as possible, consistent with total weight desired. Wherever possible the weight of parts is reduced in order to favor the boiler. It is now known that no locomotive was ever impaired in any way by having a boiler that steamed too freely, for the greater the boiler capacity the greater the speed that can be maintained. As the demand for speed and the loads hauled increased, it was soon discovered that the speed of a train of a given length and weight was limited by the capacity of the boiler. Complaints were made of the boiler "not steaming", and, although the insufficient supply of steam might have been attributed to an inferior grade of fuel, improper firing, bad adjustment, "front end" arrangement, flues in bad condition, or negligence in the manipulation of the engine, it soon became recognized that, with all boiler conditions in perfect order and the locomotive operated by experienced men, it was impossible to make a small boiler supply a sufficient amount of steam for large cylinders operating at high rates of speed. As a result the boiler gradually grew in size, and with it a desire to arrive at a rational proportioning of its various parts, such as heating surface, grate area, length of tubes, etc., necessary to maintain a definite tractive effort at a definite speed.

*Effect of Area of Heating Surface.* All the various dimensions of the different parts of the boiler are more or less important in their relation to the question of steam generation. Perhaps the most important of these are the dimensions of the heating surface. The area of the grate surface limits the amount of coal that can be burned in a given time, but the amount of coal burned per unit of heating surface governs, to a great extent, the rate of evaporation. Concerning the rate of combustion per square foot of heating surface, it is found that the same condition exists as in stationary boiler practice, namely, that the lower the rate of combustion the greater the evaporation per pound of coal.

*Effect of Tube Length.* The capacity of the boiler is also affected to a certain extent by the length of the tubes. It was found in a series of extensive experiments conducted in Europe a number of years ago that the most economical length of tubes was 14 feet. This length was found with a draft in the fire-box of 3 inches of water. In the United States a much higher draft is employed and for this reason much longer tubes can be used. Tubes over 20 feet in length are now quite common. As long as the temperature of the gases in the smoke-box is above that corresponding to the pressure of steam in the boiler there will be heat transferred from the front end of the tubes to the water in the boiler. Increasing the length of the tubes will, of course, reduce the draft in the fire-box and, as a result, the amount of coal burned will be reduced. For this reason the tubes should be of a definite length for maximum efficiency.

*Effect of Scale.* The transmission of heat through the tubes and fire-box sheets is dependent to a large extent on the condition of the inner surfaces. If they are covered with a thin layer of scale, the heat transmitted will be materially reduced. Experiments conducted in 1898 on the Illinois Central Railroad gave some very interesting results on the effect of scale on the steaming capacity of a locomotive boiler. Tests were first made on a locomotive which had been in service 21 months. After the test the engine was sent to the shops and received new tubes and a thorough cleaning. The total weight of scale removed from the boiler was 485 pounds and it had an average thickness on the principal heating surfaces of  $\frac{3}{64}$  inch. After the engine had received the cleaning and new tubes, a second test was conducted in which the same coal per square foot of heating surface was burned as in the first test. The result of the second test showed the steam-making capacity of the boiler to have been increased 13 per cent.

*Effect of Radiation.* The loss of heat from the outer surface of a locomotive boiler by radiation and the ultimate effect on its capacity are items worthy of consideration. The heat lost in this manner is so great with an unprotected boiler shell that it is necessary to use some form of insulating material to minimize the loss. Covering a boiler with insulating material is more necessary with high pressure than with low pressure because of the greater temperature difference. Results of tests of boiler covering reported to the Master Mechanics' Association in 1898 show that a loss of 0.34 B.t.u. per square foot of radiating surface per hour per degree difference in temperature was obtained by the use of mineral wool, while under the same conditions with a lagging of wood and sheet iron the loss was increased to 1.10 heat units. In both cases the temperature difference was reckoned between the temperature of the steam in the boiler and that of the surrounding air. The results show a saving of 0.76 B.t.u. in favor of the mineral wool lagging. Let us consider a boiler carrying steam at 200 pounds per square inch gage pressure, which represents a temperature of 388° F. Assuming the temperature of the atmosphere to be 32° F., this represents a temperature difference of 356 degrees. Assume further a locomotive boiler having an outside surface of 600 square feet. The heat of vaporization

per pound of steam at 200 pounds per square inch gage pressure is 838 B.t.u. The pounds of steam condensed in the boiler per hour due to radiation in case a wood lagging is used, in excess of the amount that would be condensed if mineral wool were used, is equal to

$$\frac{0.76 \times 600 \times 356}{833} = 193$$

Assuming that the steam consumption per i.h.p.hr. is 20 pounds, the above figure represents 9.6 horsepower.

The foregoing figures represent results obtained in still air. The radiation losses are increased very much when the locomotive is in service. This fact is demonstrated by the results of tests conducted on the Chicago and Northwestern Railway in 1899. The locomotive employed had 219 square feet of covered boiler surface and 139 square feet uncovered. Assuming, for this type of engine, the steam consumption per i.h.p.hr. to be 26 pounds, the results of the tests showed a condensation representing a horsepower of 4.5 when at rest and 9 when being pushed at a rate of 28 miles per hour.

*Boiler Horsepower.* In the foregoing we have considered the determination of the greatest amount of steam which a locomotive boiler can produce and it is evident that the boiler capacity limits the work that can be performed by the engine. Under some circumstances it is more convenient to express the boiler capacity in terms of an evaporative unit. The term "boiler horsepower" is such a unit, but the use of this expression is sometimes misleading in speaking of the capacity of a locomotive, for a given boiler will produce a greater horsepower with a compound than with a simple engine and with an early and economical cut-off than with a later and more wasteful one.

A *boiler horsepower*, as defined by the American Society of Mechanical Engineers, is the production of 30 pounds of steam per hour at a gage pressure of 70 pounds per square inch evaporated from a feed-water temperature of 100° F. This is considered equivalent to the evaporation of 341-1/2 pounds of water per hour from a temperature of 212° F. into steam at the same temperature.

# LOCOMOTIVE BOILERS AND ENGINES

## PART II

### THE LOCOMOTIVE ENGINE

In studying the conditions affecting the performance of the engine proper, the amount of lead, outside lap, and inside clearance must be taken into consideration.

**Lead.** By *lead* is meant the amount the steam port is open when the engine is on *dead center* or when the piston is at the beginning of its stroke. This amount varies from 0 to  $\frac{1}{4}$  of an inch in practice. By having the proper amount of lead, a sufficient amount of steam behind the piston is assured at the beginning of the stroke and assists in maintaining the steam pressure until the steam port is closed and the steam is thereby cut off. It also serves to promote smooth running machinery. Any admission of steam behind the piston before the end of the stroke results in negative work, hence the amount of lead should be limited and largely controlled by the speed of the machine.

**Outside Lap.** By the term *outside lap* is meant the amount the valve overlaps the outside edges of the steam ports when it is in its central position. One of the effects of increasing outside lap is to cause cut-off to take place earlier in the stroke, other conditions remaining unchanged. If, however, the amount of lap is increased and it is desired to maintain the same cut-off, the stroke of the valve must be increased. Within certain limits, outside lap increases the rapidity with which the valve opens the steam port, resulting in a freer admission of steam. The range of cut-off is decreased as the lap is increased, other conditions remaining the same.

When the cut-off is short, the exhaust is hastened, an effect which diminishes as the cut-off is lengthened. The amount by which the steam port is uncovered by the exhaust cavity of the slide valve is increased as the cut-off is shortened. Other things remaining constant the changing of any one of the events of stroke causes a corresponding change to a greater or less degree of each of the other events.

**Inside Clearance.** By the expression *inside clearance* is meant the amount the steam port is uncovered by the exhaust cavity of the valve when the valve is in its central position. Formerly it was customary to have an inside lap of about  $\frac{1}{16}$  of an inch but in recent years in the development of engines which require a free exhaust at high speeds, the inside lap was reduced until now there is in some cases from  $\frac{1}{8}$  to  $\frac{3}{16}$  inches inside clearance. The effect of changing a valve from inside lap to inside clearance, other things remaining unchanged, is to hasten release and delay compression and hence to increase the interval in which the exhaust port remains open. It also permits a greater extent of exhaust port opening. As a consequence, the exhaust is freer and the back pressure is reduced, giving an advantage in the operation of the engine, which is desired at high speeds. Experiments have shown that an increase in inside clearance for high speeds will bring about an increase in the power of the locomotive, but an increase in inside clearance at slow speeds entails a loss of power and a decrease in efficiency. The loss in power at low speeds, due to inside clearance, is greater at short cut-offs and diminishes as



the cutoff is increased. Tests have shown that at moderate speeds, say, 40 to 50 miles per hour, all disadvantages are overcome.

## VALVE MOTION

**Requirements.** The valve motion of a locomotive engine must meet the following regulations:

1. It must be so constructed as to impart a motion to the valve which will permit the engine to be operated in either direction.
2. It must be operative when the engine is running at a high or low speed and when starting a heavy load.
3. It should be simple in construction and easily kept in order.

A number of valve gears have been developed which fulfill these requirements more or less satisfactorily, such as the Stephenson, the Walschaert, the Joy, and the fixed link, the Stephenson gear being the one most commonly used in the United States. A study will be made of the Stephenson and Walschaert gears, the latter resembling in some respects the Joy valve gear. The Walschaert gear has been extensively used in Europe for many years and of late years has become quite common in America. There are a few modifications of the Stephenson gear which have been made to meet structural requirements but the great majority of American engines are fitted with a device as illustrated in [Fig. 64](#). The action of this device is fully explained in the article on "Valve Gears."

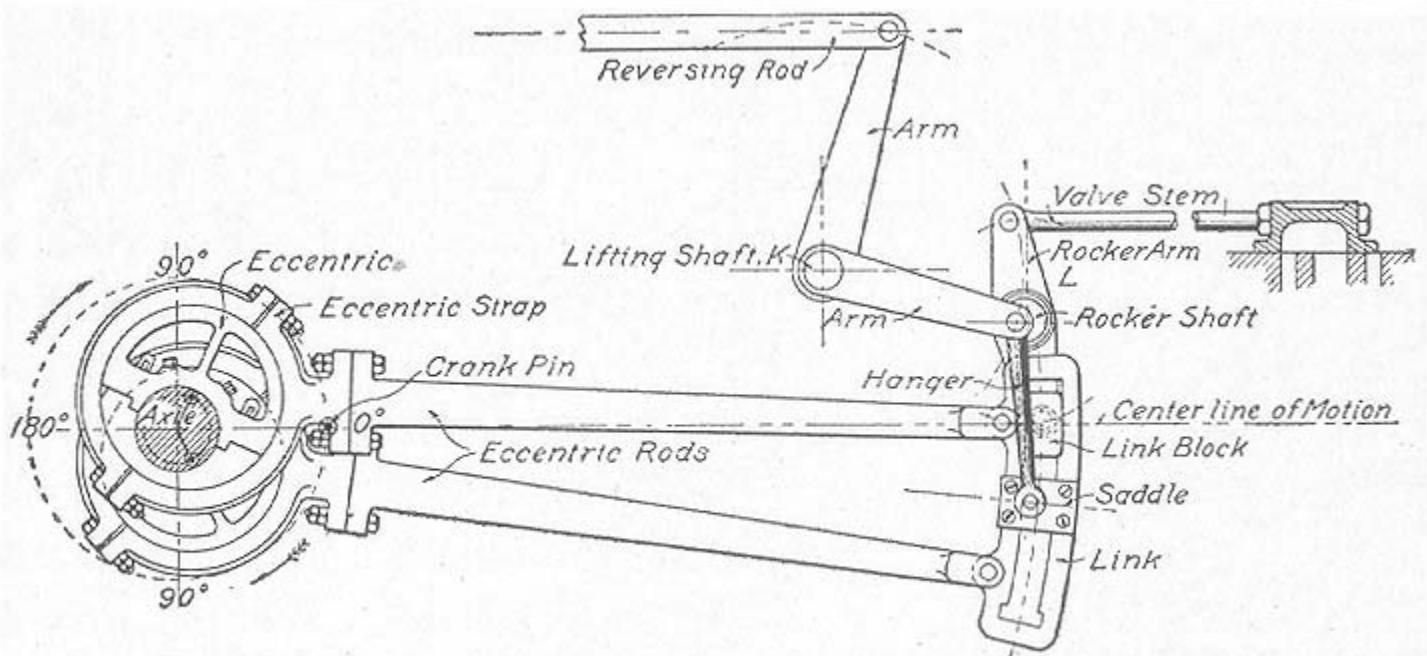

Fig. 64. Standard Stephenson Valve Gear.

**Stephenson Valve Gear.** The Stephenson gear consists of the reverse lever, reach rod, lifting shaft, link hanger, link, eccentric, and rocker arm.

The *reversing lever* is given a variety of forms, a good design of which is illustrated in [Fig. 65](#). The lever is pivoted at *A*, below the floor of the cab and can be moved back and

forth beside the quadrant *B* to which it can be locked by means of the latch *C*. This latch is held down by a spring surrounding the rod *D*, acting on the center of the equalizer *E*. This makes it possible to use very fine graduations of the quadrant and by making the latch as shown, the cut-off can be regulated by practically what amounts to half notches.

The *reach rod*, or *reversing rod*, is fastened to the reversing lever at *F* and consists of a simple piece of flat iron having a jaw at one end by which it serves to connect the reversing lever and the lifting shaft *K*, shown in [Fig. 64](#).

The *lifting shaft*, shown at *K*, [Fig. 64](#), consists of a shaft held in brackets usually bolted to the engine frames to which are connected three arms, one being vertical and to which is attached the reach rod, and two horizontal ones from which the links are suspended.

The *link hanger* is a flat bar with a boss on each end. It carries the link by means of a pin attached to the link saddle, illustrated in [Fig. 64](#).

The *link*, [Fig. 64](#), is an open device held by the saddle and fitted with connections for the eccentric rod.

The *eccentrics*, [Fig. 64](#), usually of cast iron, are fitted to the main driving axle.

The *rocker arm*, [Fig. 64](#), consists of a shaft to which two arms are connected, the lower one of which is attached to the link block and the upper to the valve stem.

*Setting the Valves.* This is a comparatively simple operation but one requiring great care. On account of the angularity of the rods, it is impossible to adjust any link motion to give equal cut-off at all points for both strokes of the piston. The most satisfactory arrangement is one which provides for an equalization of the lead and cut-off at mid-gear. But even this will cause a variation of cut-off of from  $\frac{3}{8}$  to  $\frac{1}{2}$  of one per cent in the full gear part of the cut-off and at other points.

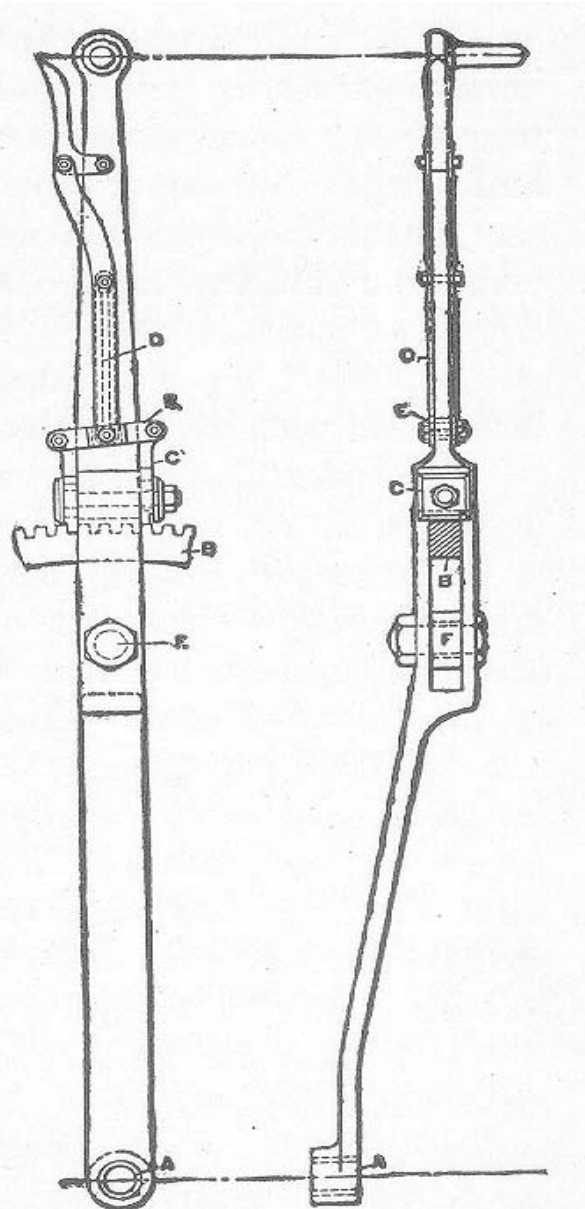

Fig. 65. Reversing Lever.

In setting the valves upon a locomotive, some means must be employed for turning the main driving wheels. This is usually accomplished by mounting the main drivers upon small rollers which can be turned by a ratchet or motor without moving the locomotive as a whole. If a set of rollers are not available, the locomotive may be moved to and fro by using pinch bars.

Before undertaking the setting of the valves, the length of the valve rod must be adjusted. To do this, set the upper rocker arm vertical if the valve seat is horizontal; if inclined, the rocker arm must be placed perpendicular to the plane of the valve seat. Next adjust the length of the valve rod so that it will connect with the rocker arm and the valve when the valve is in its central position. The next step is to locate the dead center points which points give the position of the crank on the dead center. It is very essential that this be done very accurately since a small movement of the crank at this position moves the piston but very little while the same movement causes a comparatively large movement of the valve. Hence, if the dead center points are not accurately located, the valves will not be set so accurately as they otherwise would be. To locate the dead center points, proceed as follows: First, secure a tram *d* as shown in [Fig. 66](#). This tram should be made of a steel rod about 1/4 inch in diameter having each end pointed, hardened, and tempered so as to retain a sharp point. With a center punch, make a center *e* on some fixed portion of the frame in such a position that when one point of the tram is in the

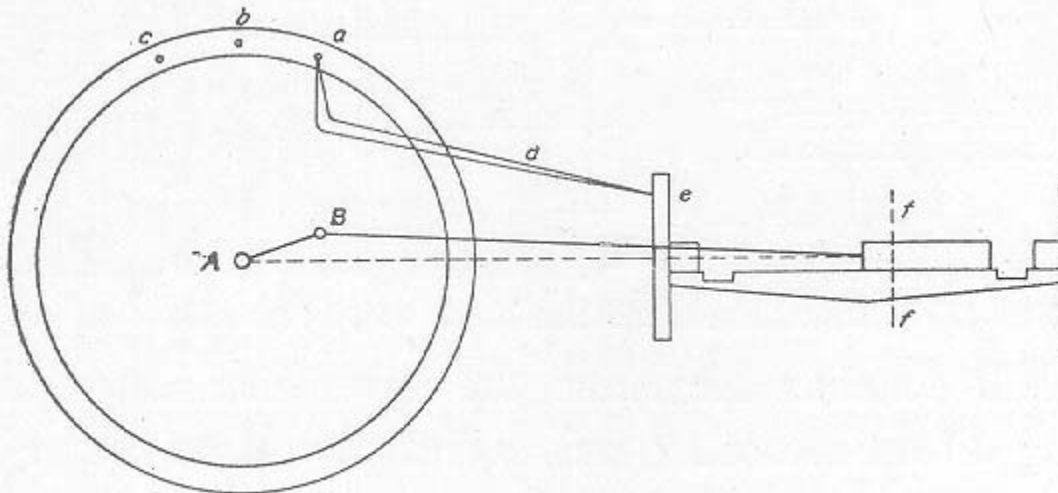

Fig. 66. Diagram for Locating Dead-Center Points.

center *e*, the other pointed end can be made to describe lines on the main driver. To locate the forward dead center, turn the driver ahead until the crank has almost reached the center line as shown in the position *AB*, [Fig. 66](#); that is, when the crosshead is, say, 1/2 inch from the extreme point of its travel. With the parts in this position, place the tram point in *e* as shown and locate the point *a* on the driver, and describe the line *ff* on the crosshead and guide. Next turn the driver ahead until the crank passes the dead center and the lines *ff* again coincide, when a second point *c* is marked by means, of the tram at the same distance from the center of the axle as the point *a*. With a pair of dividers locate the midposition *b* between *a* and *c*. In setting the valves for the head end, the required dead center will be located when one tram point is in the center *e* and the other in the center *b*. The dead-center point for the back stroke is located in the same manner as just described. An attempt to place the engine on dead center by measurements taken on the crosshead alone would likely result in an error, since the crank might move through an appreciable angle while passing the dead center and the consequent movement of the crosshead be

inappreciable, hence the advisability of using the more exact method explained above is made apparent.

The reverse lever and all the parts having been connected, to set the valves for forward gear, the procedure is as follows: Place the reverse lever in its extreme forward position. When this is done turn the engine ahead until the valve is just beginning to cut off, as shown at *l*, [Fig. 67](#). When this point is reached, stop the engine and make a small punch mark such as *a* on the cylinder casting. Then put one end of the tram *b* into the punch mark and describe an arc *c e* on the valve stem. Next turn the driver ahead until the valve is just cutting off on the other end. With the same center *a* as used before, describe another arc *f g* on the valve stem. These two arcs are known as the port lines and are to be the reference lines for the work which follows. Draw a straight horizontal line *H I* on the valve stem and where it intersects the arcs, make the center marks *A B*. The center *A* is the front port mark and the center *B* the back port mark. Next, place the reverse lever in the extreme backward position and locate points on the valve stem similar to the points *A* and *B*.

To avoid confusion, it is better to make all tram marks for the forward movement above the line *H I* and all those for the backward motion below.

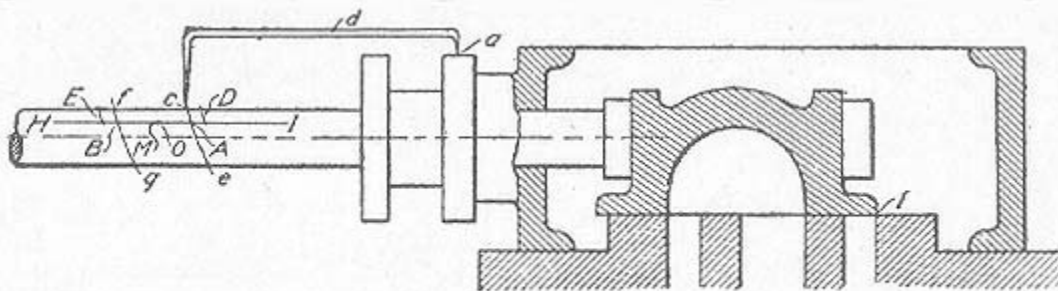

Fig. 67. Illustration of Method of Setting Locomotive Valves.

In trying the forward movement of the valve, see that the reverse lever is in the extreme forward position, then by running the engine ahead, place the crank in turn on each dead center, and describe an arc on the valve stem. In trying the valve for the backward gear, place the reverse lever in its extreme back position and by running the engine backward, place the crank on each dead center and describe arcs on the valve stem as before. In either case, if the dead center is past, do not back up to it but either make another revolution of the engine or back beyond it some distance, then approach it from the proper direction. This must be done in order to eliminate all lost motion.

These trial tram lines should be compared with the port marks when the engine is placed in the forward and backward gear.

If the trial tram lines fall outside of the port marks, so much lead is indicated, while if they fall within the port marks, so much negative lead is indicated.

It is customary for railroad companies to set the valves on their locomotives to give equal lead. The method commonly employed is presented herewith. Having the reverse lever in the extreme forward notch, run the engine ahead, stopping it on the forward dead center. With the tram *b* in the center *a*, [Fig. 67](#), describe the arc *D* above the line *H I*. Next turn the engine ahead until the back dead center is reached; using the tram *b* again with a



center at  $a$ , describe the arc  $E$  above the line  $HI$ . With dividers, find a mid-point  $O$  between  $E$  and  $D$ . If the center  $O$  is ahead of the point  $M$ , which is midway between the port marks  $A$  and  $B$ , the eccentric blades which control the forward motion must be shortened an amount equal to the distance between  $M$  and  $O$ . When this is done, the lead will be equalized. If it is desired to increase the lead, move the forward eccentric toward the crank. To decrease the lead, move the forward eccentric away from the crank. After all of these changes have been made, repeat the operation in order to check the results. If this does not give the desired results, correct the error by repeating the process and continue by trial until the conditions sought for are obtained.

To set the valves for the back motion, proceed in the same manner as that described for the forward motion, all the changes being made on the eccentric blades and eccentric which control the backward motion.

In all that has been said regarding the setting of the Stephenson valve gear, it is assumed that the gear is one having open rods; that is, one in which the rods are open, not crossed when the eccentrics face the link.

**Walschaert Valve Gear.** The Walschaert valve gear is illustrated by the line diagram in [Fig. 68-a](#). [Fig. 68-b](#) shows its application to a Consolidation freight locomotive. From a study of [Fig. 68-a](#) it is obvious that the motion of the valve is obtained from the crosshead and an eccentric crank attached to the main crank pin. In some designs, the eccentric pin is replaced by the usual form of eccentric attached to the main driving axle. The crosshead connection imparts a movement to the valve which in amount equals the lap plus the lead when the crosshead is at the extremities of the stroke, in which position the eccentric crank is in its mid-position. The lead of the valve is constant and can only be changed by altering the leverage relation of the combination lever. The eccentric crank actuates the eccentric rod which, in turn, moves the link to and fro very much the same as does the eccentric blade in the Stephenson gear. There is a radius bar, [Fig. 68-a](#), which connects the link block with the valve stem. It is evident, therefore, that the valve obtains a motion from the eccentric crank, link, radius bar, and valve rod in a manner similar to the Stephenson, the main difference being in the crosshead connection which results in giving the valve a constant lead.

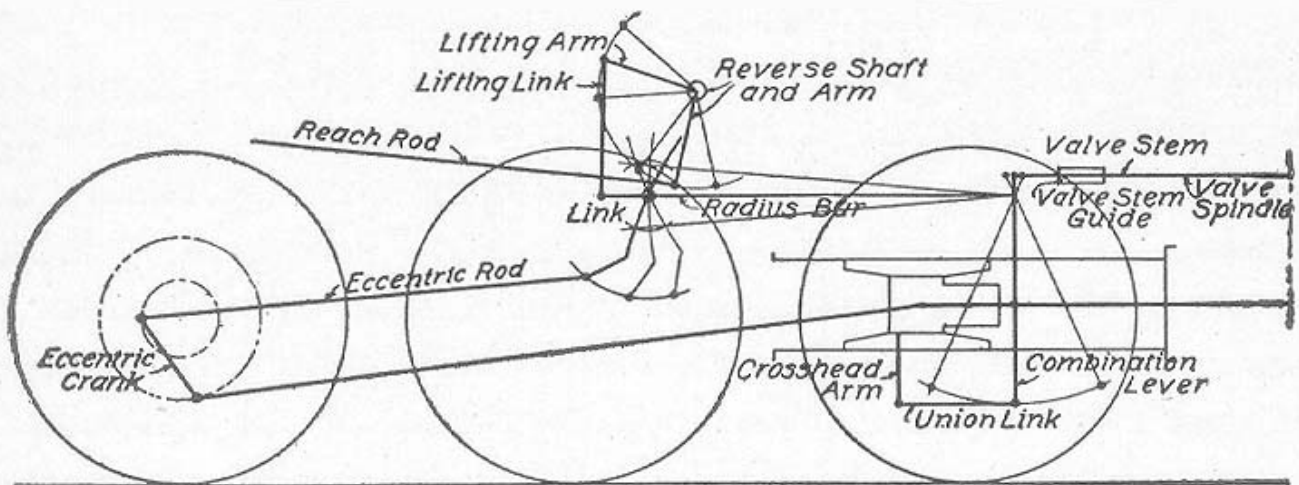

Fig. 68-a. Diagram of Walschaert Valve Gear.

It is to be noted that in a valve having internal admission, the radius bar connects with a combination lever above the valve rod connection, as shown in [Fig. 68-b](#), and that in a valve having external admission, the connection is made below the valve rod, as illustrated in [Fig. 68-a](#); also, in a valve having internal admission, the eccentric crank follows the main crank, while in a case where the valve has external admission, it precedes the main crank. Theoretically, the eccentric crank is 90 degrees from the main crank but because of the angularity of the eccentric rod, it is usually two or three degrees more.

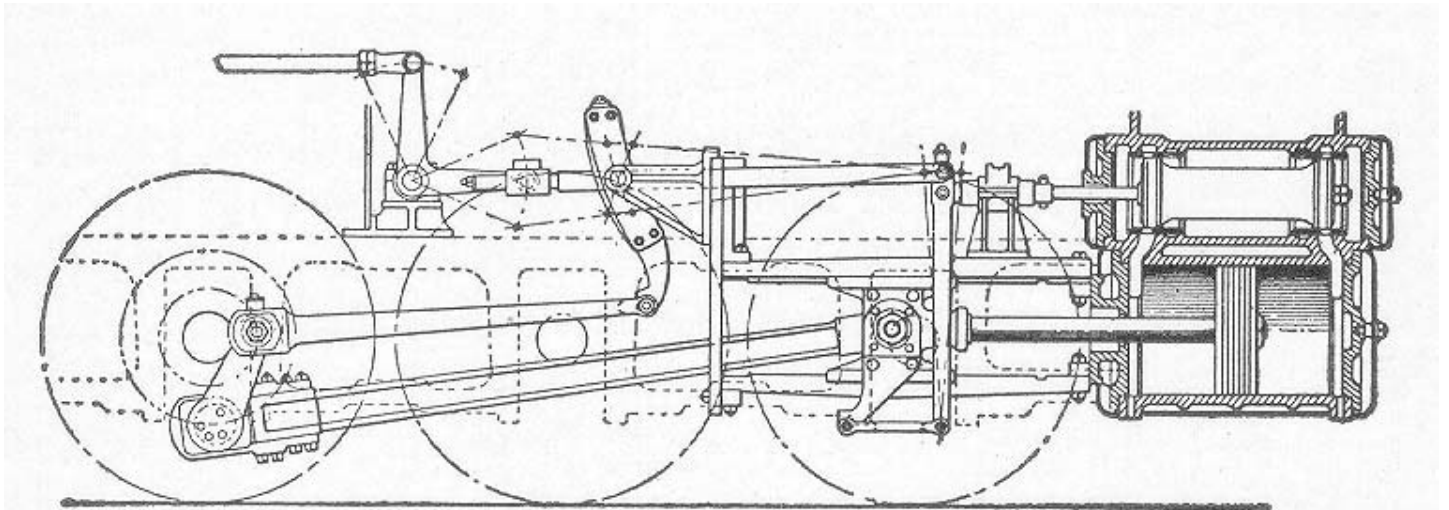

Fig. 68-b. Walschaert Gearing Mounted on a Consolidation Locomotive.

The Walschaert gear is operated by a reverse lever in the same manner as the Stephenson gear. In the Stephenson gear, a movement of the reverse lever causes the link to be raised or lowered, the link block remaining stationary, whereas in the Walschaert gear, the link remains stationary and the link block is raised or lowered. From a study of the two gears, it may be stated that the chief point of difference is that the Walschaert gives a constant lead for all cut-offs, whereas the Stephenson gives a different lead for different cut-offs. The following steps given by the American Locomotive Company for adjusting the Walschaert valve gear are presented:

1. The motion must be adjusted with the crank on the dead centers by lengthening or shortening the eccentric rod until the link takes such a position as to impart no motion to the valve when the link block is moved from its extreme forward to its extreme backward position. Before these changes in the eccentric are resorted to, the length of the valve stem should be examined, as it may be of advantage to plane off or line under the foot of the link support which might correct the length of both rods, or at least only one of these would need to be changed.
2. The difference between the two positions of the valve on the forward and back centers is the lead and lap doubled and it cannot be changed except by changing the leverage relations of the combination lever.
3. A given lead determines the lap or a given lap determines the lead, and it must be divided for both ends as desired by lengthening or shortening the valve spindle.
4. Within certain limits, this adjustment may be made by shortening or lengthening the radius bar but it is desirable to keep the length of this bar equal to the radius of the link in order to meet the requirements of the first condition.
5. The lead may be increased by reducing the lap, and the cut-off point will then be slightly advanced. Increasing the lap introduces the opposite effect on the cut-off. With good judgment, these qualities may be varied to offset other irregularities inherent in transforming rotary into lineal motion.



- Slight variations may be made in the cut-off points as covered by the preceding paragraph but an independent adjustment cannot be made except by shifting the location of the suspension point which is preferably determined by a model.

**Comparison between Stephenson and Walschaert Gears.** A comparison of the Stephenson and Walschaert valve gears shows that steam distribution in former would not differ to a very great extent from that in the latter save in that produced by the constant lead.

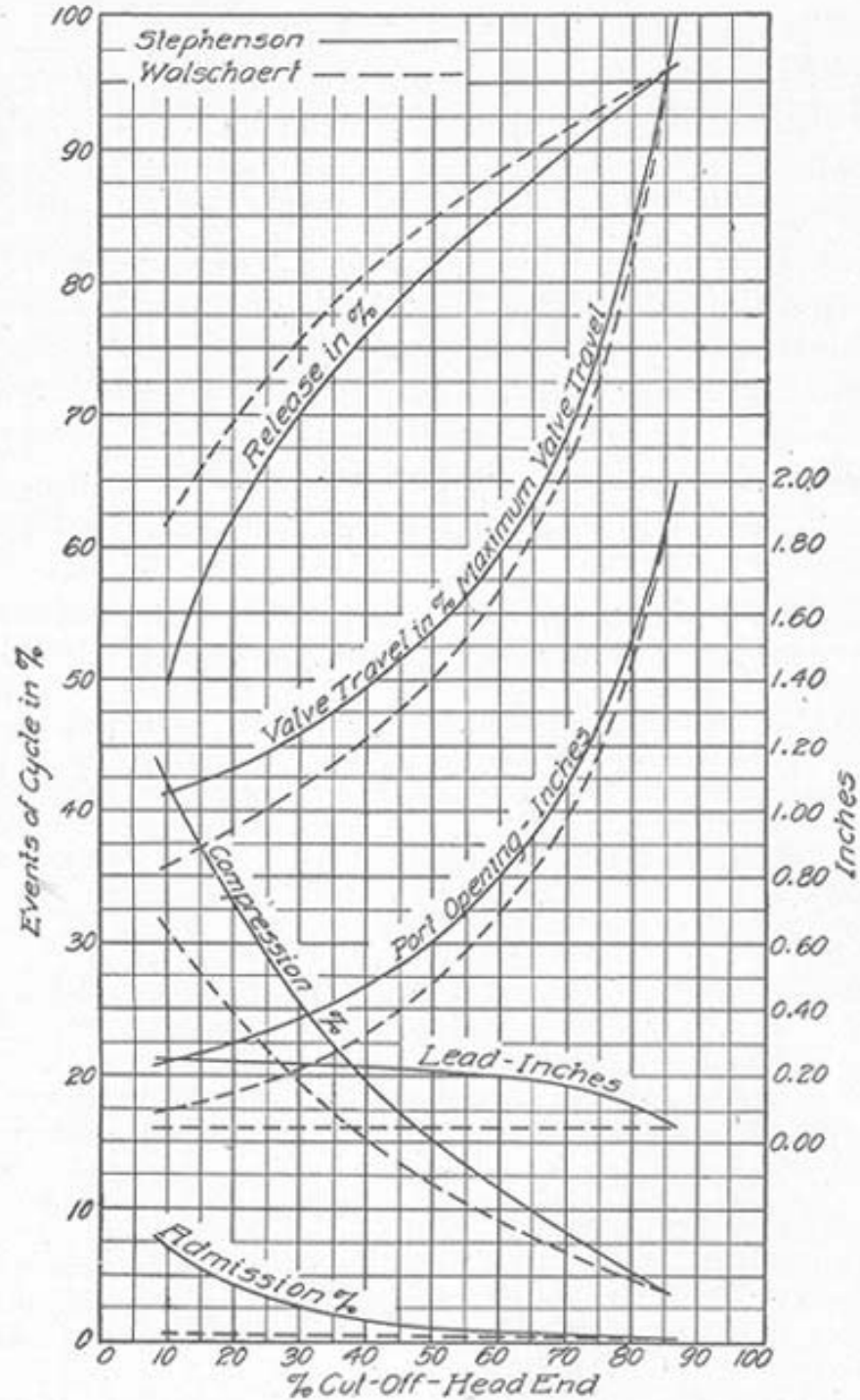

Fig. 69-a. Curves Showing Events for Head End of Forward Motion for Stephenson and Walschaert Gears.

The factors in favor of the Walschaert gear are largely mechanical ones which may be designated as *easily accessible parts* and a *less amount of care in maintenance*. The parts making up the Walschaert valve gear are outside of the frames where they can be easily reached in case of breakdowns and necessary repairs. Another advantage accruing from this fact is that the space between the frames is left open permitting bracing, which protects and strengthens the frames. This is not possible when the Stephenson gear is used. The smaller number of moving parts, hardened pins, and accessible bearings in the Walschaert gear result in fewer and less expensive repairs.

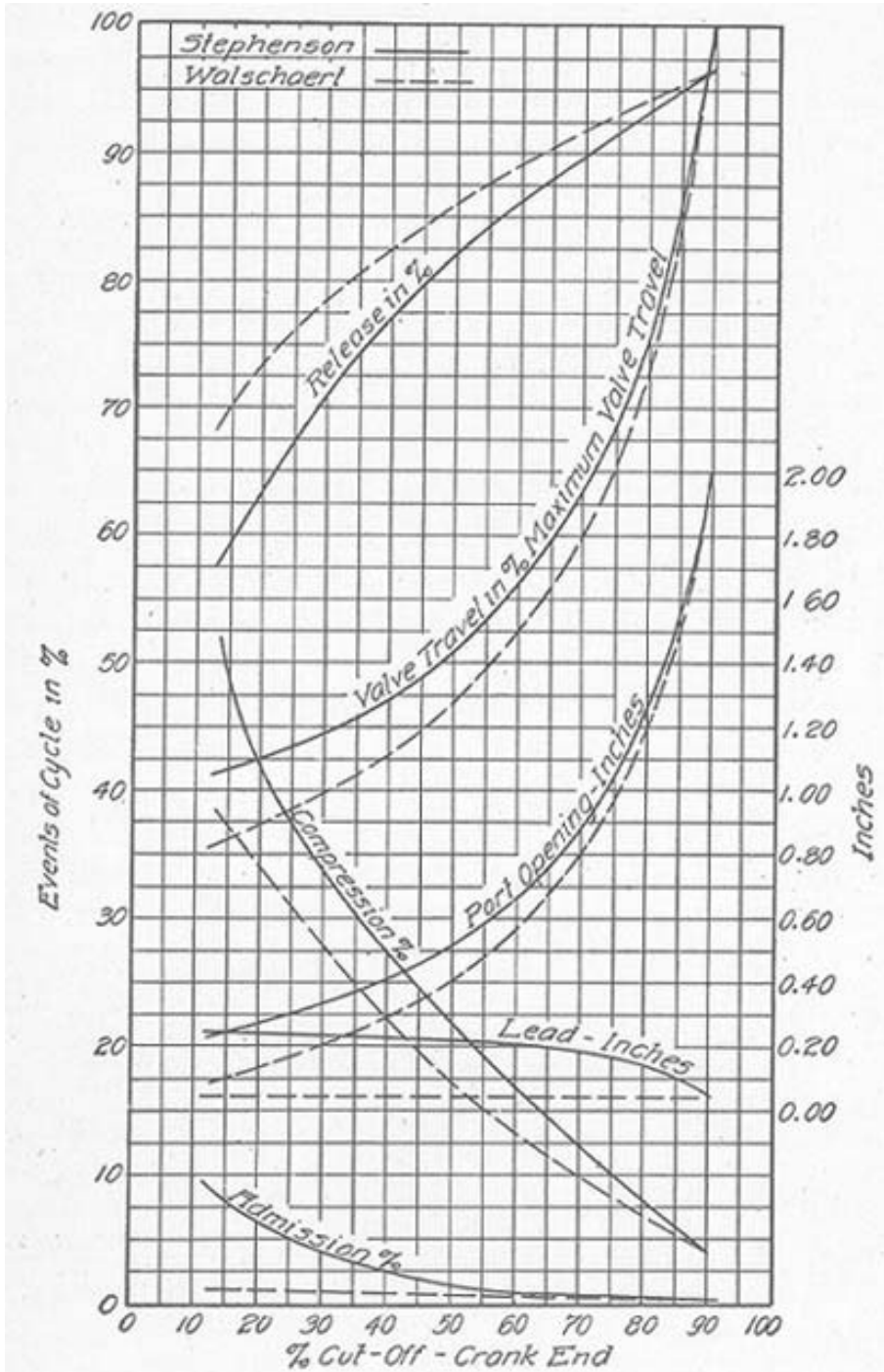

Fig. 69-b. Curves Showing Events for Crank End of Forward Motion for Stephenson and Walschaert Gears.

A study of the action of a valve on a given locomotive, when operated by means of a Walschaert gear and also a Stephenson gear, gave the results shown graphically in [Figs. 69-a](#) and [69-b](#). The results were taken from Zeuner diagrams, drawn to represent the steam distribution given by each gear. The general dimensions of the two gears, taken from designs prepared for use on a given locomotive are shown in Table VIII.

The conditions for both the head end and crank end of the forward motion, in both Stephenson and Walschaert gears are represented in [Figs. 69-a](#) and [69-b](#). Each event of the cycle-valve travel, port opening, and lead-is plotted with reference to the cut-off. As can be seen, the Walschaert gear gives for all cut-off positions a later admission, later release, later compression, less lead, less port opening, and less valve travel than does the Stephenson gear. With the exception perhaps of lead, the differences are negligibly small for all cut-off positions beyond 50 per cent. With cut-off positions less than 50 per cent, however, these differences increase quite rapidly.

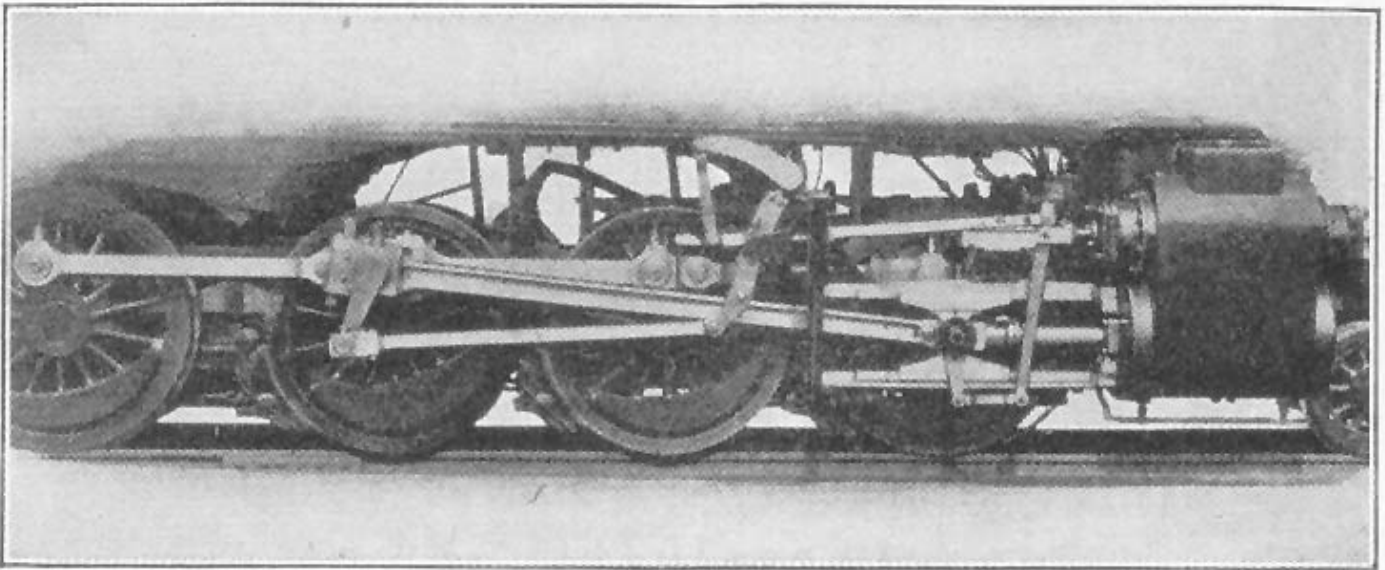

Fig. 69-c. Walschaert Valve Gear Mounted on Consolidated Freight Locomotive.

The Walschaert gear is applied to a locomotive in several ways, each having its own advantages. The method illustrated in [Fig. 69-c](#) gives the student a general idea how the scheme is worked out and applied in connection with a consolidative freight locomotive.

**TABLE VIII**

**Comparative Dimensions of Stephenson and Walschaert Gears**

	Stephenson Gear	Walschaert Gear
Type of valve	D-Slide	D-Slide
Steam lap in inches, H.E.	1.0	1.0
Steam lap in inches, C.E.	1.0	1.0
Exhaust lap in inches, H.E.	0	0
Exhaust lap in inches, C.E.	0	0
Lead at full gear in inches	3/64	3/64
Lead at mid gear in inches	1/4	3/64
Width of port in inches	1	1
Maximum valve travel in inches	6	6
Stroke of piston in inches	24	24
Length of connecting rod in inches	96	96
Radius of link arc in inches	60	
Length of radius rod in inches		46

**Valves.** Until recent years the valve ordinarily used on locomotives was the *plain slide valve*, partially balanced. In the plain slide valve the full steam chest pressure is exerted over the whole of the back surface of the valve. The balancing of a valve consists in removing a portion of this pressure, thus decreasing the frictional resistance of the valve on its seat.

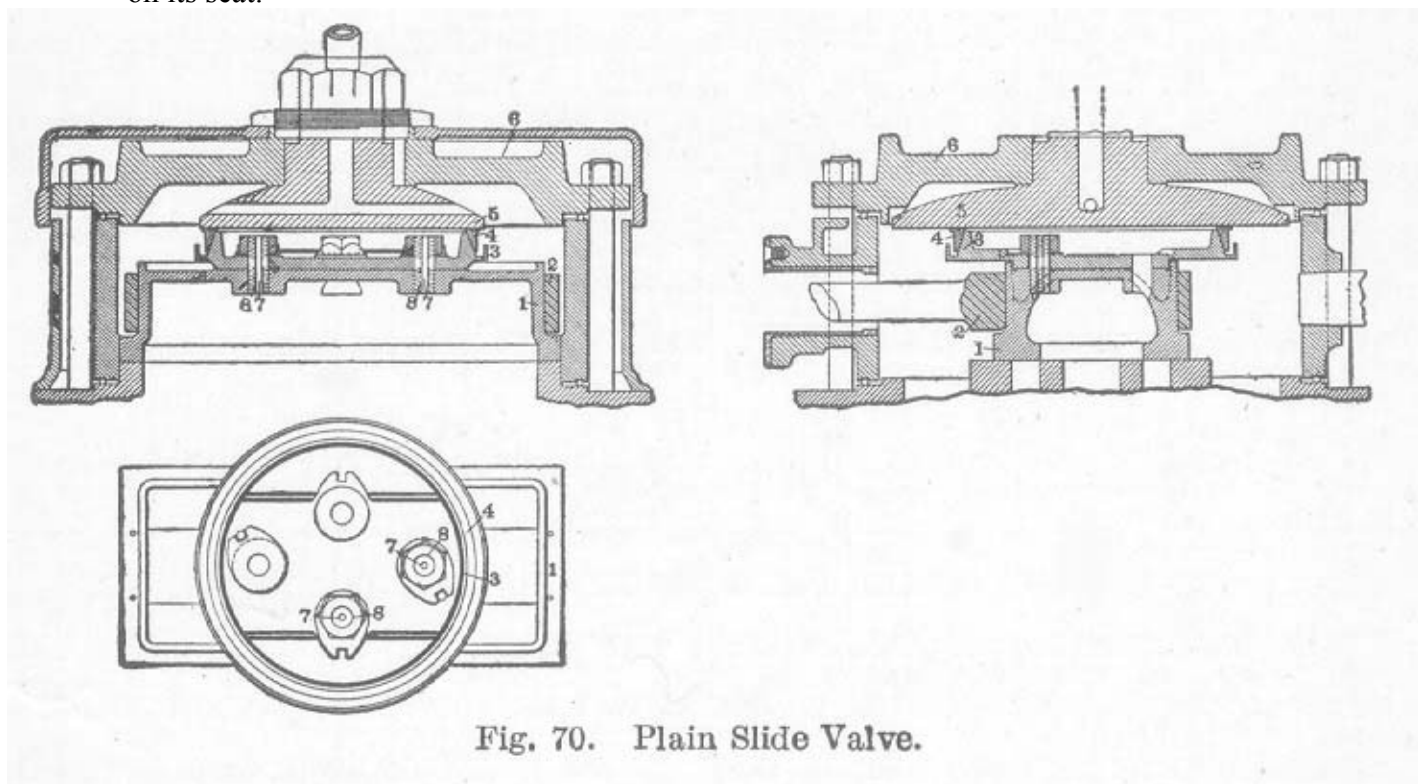

**Fig. 70. Plain Slide Valve.**

The percentage of this pressure that is removed, or the *amount of balance*, varies from 45 to 90 per cent of the total face of the valve, and the average in practice is about 65 per cent. In the valve shown in [Fig. 70](#), the balance is 69 per cent. The pinch of the packing ring on the cone slightly increases the pressure of the valve on its seat. In [Fig. 70](#), the valve, 1, is of the ordinary D type driven by the yoke, 2, which is forged as a part of the valve stem. To the back of the valve is bolted a circular plate, 3, having a cone turned thereon. On this cone is fitted a loose ring, 4, the inner face of which is beveled to the same degree as the taper of the cone. The ring is cut at one point and is, therefore, flexible. The open space at the cut in the ring is covered by an L-shaped clip which is placed on the outside and fastened to one end of the ring, the other end of the ring remaining free. This L-shaped clip reaches to the top of the ring at the outside and under the ring at the bottom to the taper of the cone. It thus forms joints just the same as the ring itself, making a continuous yet flexible ring. The ring is made of cast iron and is bored smaller than the diameter required for the working position. Therefore, before the steam chest cover is placed in position, it sets slightly higher on the cone than it does when at work. To the inner side of the steam chest cover, 6, is bolted a back plate, 5, against which the ring, 4, forms a steam tight joint. Owing to the raised position of the ring when first put on, the placing of the cover and the back plate forces the ring down over the cone. This expands the former to a larger diameter and it is thus held in its expanded position under tension with the tendency to maintain the joint between itself and the wearing plate.

Another method employed in balancing a slide valve is to cut grooves in the top of the valve which extend across the four sides of the valve. In these grooves are placed carefully fitted narrow strips which rest on small springs which keep the strips pressed up against a pressure plate, thus keeping the steam away from a large part of the valve.

In order to provide for any leakage which may occur past the ring and to prevent an accumulation of pressure within the same, the holes, 7, are drilled through the studs, 8. These drain the space and accomplish the desired result.

A relief valve is placed on the steam chest. This is a check valve opening inward and serves to equalize the pressure in the two ends of the cylinder when the locomotive is coasting, thus preventing unequal pressure at either end.

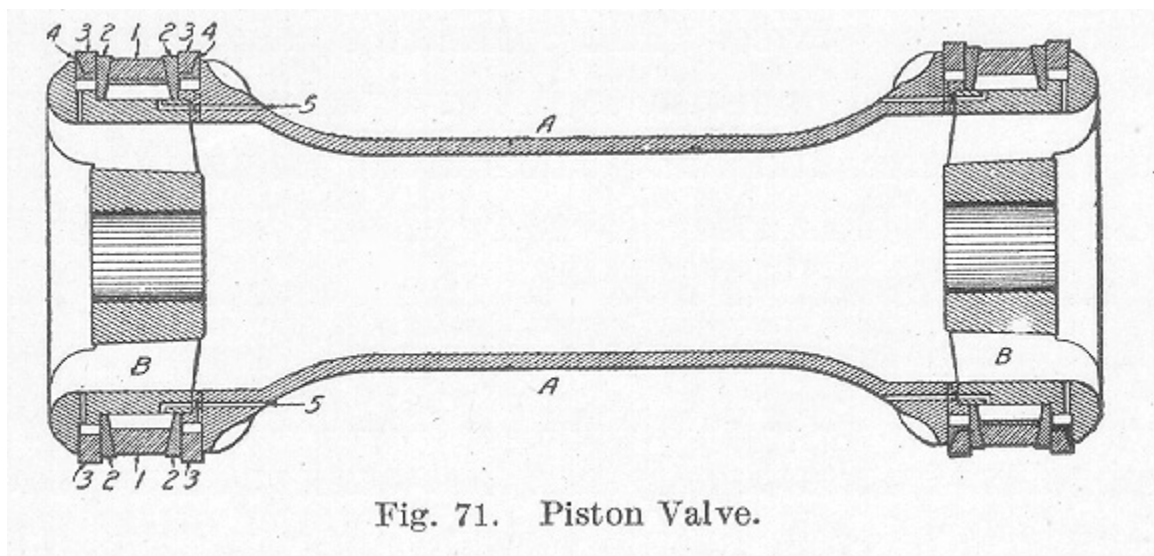

Fig. 71. Piston Valve.



Another form of valve which is now being extensively used is the piston valve, illustrated in [Fig. 71](#). In this valve, the steam is admitted at the center in the space *A* and is exhausted at the ends. Such valves are self-balanced since they are entirely surrounded by steam. Another form of piston valve is constructed with a passage extending through its entire length which connects with a live steam passage. In this type of valve, steam is admitted at the ends of the valve at *B*, and when exhausted passes around the circular part *A* to the exhaust cavity. In piston valves, it only remains to pack the ends to prevent steam leaks. This is done by using packing rings. [In Fig. 71](#), the packing consists of seven pieces at each end, numbered 1, 2, 3, and 4. Numbers 3 and 4 are the packing rings proper. They consist of the split rings, 3, and the L-shaped covering piece, 4, for the split in No. 3. The rings, 2, are solid and serve merely as surfaces against which the rings, 3, have a bearing. The wedge ring, 1, is split and can expand. The rings, 3, are turned larger than the diameter of the steam chest and are sprung into position. Small holes, 5, are drilled from the steam space *A* to a point beneath the wedge ring, 1. When the throttle valve is opened, steam enters the holes, 5, forcing the wedge, 1, out between the rings, 2. It locks the packing ring, 3, firmly between the ring, 2, and the lip of the valve. This prevents rattling and working loose of the rings, making the valve practically steam-tight.

A form of packing largely used and which is much simpler than the above, consists of ordinary snap rings inserted into annular grooves cut around the heads of the valves.

**Valve Friction.** Of the many different parts of a locomotive which have been studied from the scientific standpoint, few parts have been given more attention than the main steam valve. When the valves were small and steam pressures were not high, the force necessary to move the valve when in operation was not very great. With the pressures employed today and the sizes of steam ports found on our modern locomotives, the reduction of valve friction becomes a very important matter. From an examination of [Figs. 70](#) and [71](#), it is an easy matter to see that the more completely a valve is balanced, the less work will be required to move it back and forth when in service.

*Valve Tests to Determine Friction.* The question was considered such an important one that the Master Mechanics' Association appointed a committee to investigate different types of valves under conditions of service. The committee conducted its experimental work, in 1896, upon the locomotive testing plant at Purdue University, Lafayette, Indiana. The Purdue locomotive, known as Schenectady No. 1, was used, having cylinders 17 inches in diameter by 24 inches stroke. The ports were 16 inches long, the steam port being 1-1/4 and the exhaust port 2-1/2 inches wide. The bridges were 1-1/8 inches wide. The valve had a maximum travel of 5-1/2 inches, steam lap, 3/4-inch, exhaust lap, 1/32-inch, and was set with a 1/16-inch lead, with the reverse lever in its full forward position, and a 7/32-inch negative lead, with the reserve lever in its full backward position.

Four different slide valves were tested as follows: unbalanced D-valve, Richardson balanced valve, American balanced valve with single balance ring, and American balanced valve with two balance rings. A fluid dynamometer was placed in position between the valve stem and rocker arm in such a manner as to measure the force necessary to overcome the friction of the valve when operated under different conditions. The valves weighed 78, 85-1/2, 79-1/4, and 84 pounds, respectively. The weight of the dynamometer was 105 pounds and that of the valve yoke 37 pounds. The Richardson valve had 56 per cent of the area of the valve face balanced by the use of flat strips held



against the balance plate by springs. The American valves had 61-1/2 ,and 66 per cent of their areas balanced by using single and double balancing rings, respectively.

The power required to operate the different valves was determined by means of the fluid dynamometer to which was attached a steam engine indicator. The arrangement was such that pressure diagrams could be taken in which the length corresponded to the stroke of the valve and the height to the pressure of the fluid on the piston of the dynamometer. Tests were conducted at different cut-offs and speeds. A few of the results secured are presented in Tables IX and X.

**TABLE IX**

**Valve Tests Showing Mean Pull in Pounds for Different Valves**

(Steam Chest Pressure, 100 Pounds per Square Inch)

Cut-Off in Inches	22			9-1/2		
	10	20	40	10	20	40
<b>Richardson</b>	382	396	772	361	442	468
<b>American single</b>	.....	522	872	394	535	591
<b>American double</b>	.....	488	762	412	500	568
<b>Unbalanced</b>	1118	1062	1207	1322	1240	1180

**TABLE X**

**Valve Tests Showing Per Cent of I.H.P. of One Cylinder Required to Move Valve**

Cut-Off in Inches	22			9-1/2		
	10	20	40	10	20	40
<b>Richardson</b>	0.43	0.49	1.54	0.32	0.34	0.61
<b>American single</b>	0.48	0.65	1.91	0.27	0.40	0.67
<b>American double</b>	.....	0.61	1.66	0.27	0.45	0.63
<b>Unbalanced</b>	1.20	1.30	2.42	0.82	.....	1.62

The committee in their report to the society stated that the friction or resistance of unbalanced valves was about twice as great as that of balanced valves and recommended that the area of balance should equal the area of the exhaust port plus the area of the two bridges plus the area of one steam port. As a result of the work done by the committee and by some of the railway companies, it soon became evident that the D-valve for locomotive work was very inefficient. For this reason, in recent years the piston type of valve, which in itself is balanced, is being almost universally used.

## RUNNING GEAR

The running gear of a locomotive is composed of the following important parts: Wheels, axles, rods, pistons, and the frames which form a connection between these parts.

**Wheels.** The driving wheels have a cast-iron or steel center protected by a steel tire. Until about 1896, cast iron was universally employed for wheel centers and is yet used for the smaller engines.

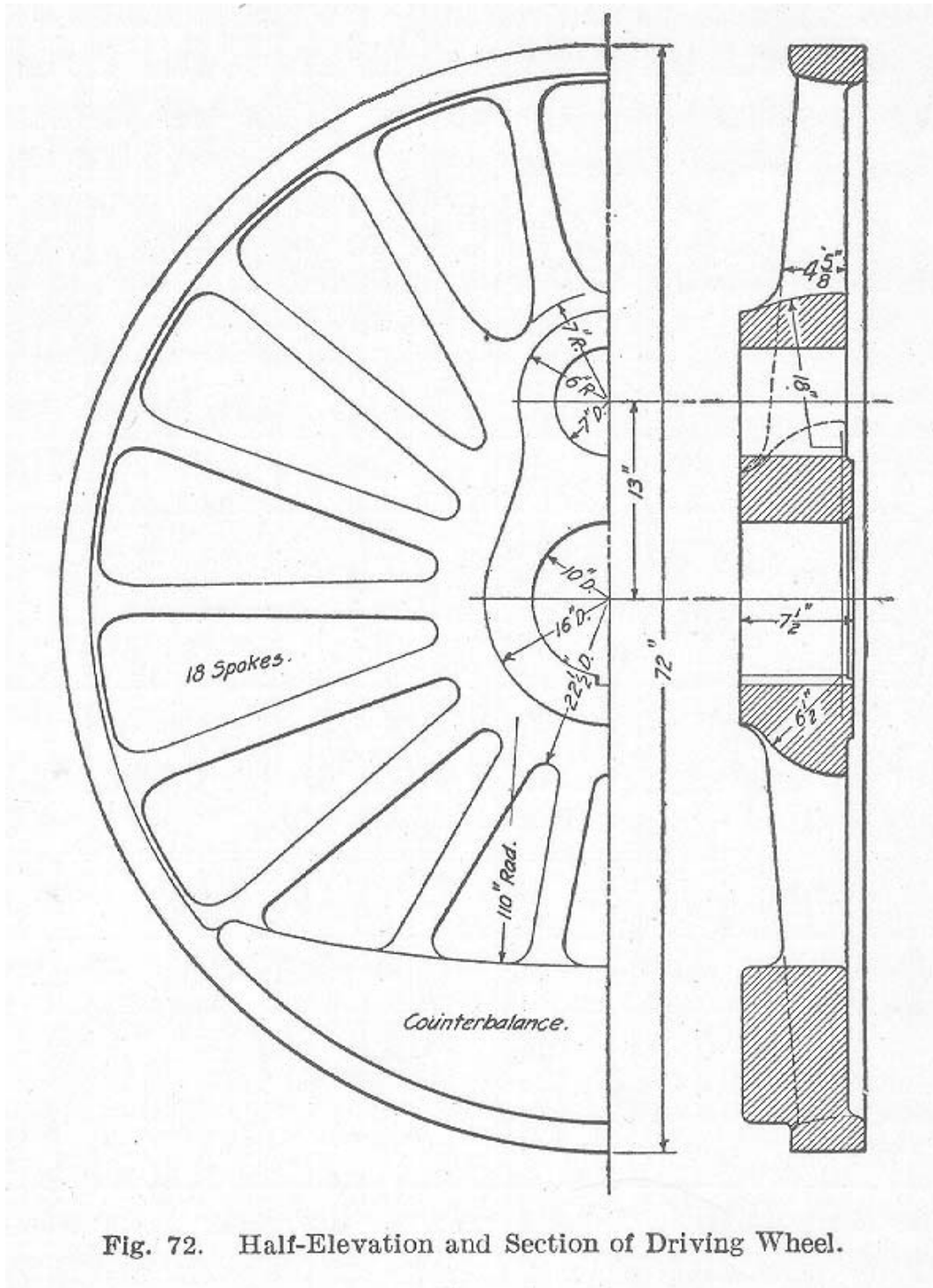

For engines having large cylinders, where a saving of weight is important, cast steel is now used makes possible a considerably lighter construction. Such a wheel is illustrated in [Fig. 72](#). The universal method of fastening on the tire is to bore it out a trifle smaller than the diameter to which the center is turned, then expand it by heating and after slipping it over the center allow it to contract by cooling. The shrinkage commonly used is 1/80 of an inch for each foot diameter of wheel center for all centers of cast iron or cast steel less than 66 inches in diameter. For centers more than 66 inches in diameter, 1/60 of an inch for each foot diameter is allowed for shrinkage. This gives the following shrinkages:

**TABLE XI**

**Shrinkage Allowance**

Diameter of Center	Shrinkage	Bored Diameter of Tire
56	.058	55.94
58	.060	57.94
60	.063	59.93

The American Master Mechanics' Association recommends the following concerning wheel centers:

In order to properly support the rim and to resist the tire shrinking, the spokes should be placed from 12 to 13 inches apart from center to center, measured on the outer circumference of the wheel center. The number of spokes should equal the diameter of center expressed in inches divided by 4. If the remainder is <sup>^</sup> or over, one additional spoke should be used. The exact spacing of the spokes according to this rule would be

$$3.1416 \times 4 = 12.56 \text{ inches}$$

Wheel centers arranged in this manner would have the following number of spokes:

**TABLE XII**

**Spoke Data - General**

Diameter of Centers	Number of Spokes	Diameter of Centers	Number of Spokes
38	10	72	18
44	11	74	19
50	13	76	19
56	14	78	19
62	16	80	20
66	17		

Among pattern makers and foundry men, there is an impression that an uneven number of spokes should be used so as to avoid getting two spokes directly opposite each other in a straight line. The following table has been made up on this basis:

**TABLE XIII****Spoke Data - Foundry Rule**

<b>Diameter of Center</b>	<b>Number of Spokes</b>	<b>Pitch</b>
44	11	12.5
48	11	13.6
50	13	12.6
54	13	13.0
56	13	13.5
60	15	12.6
62	15	13.0
66	15	13.8
68	17	12.5
70	17	12.9
72	17	13.3
74	17	13.6
76	19	12.6
78	19	12.9

The spokes at the crank hub should be located so that the hub will lie between two of the spokes and thus avoid a short spoke directly in line with the crank pin hub.

Cast steel driving wheel centers should be preferably cast with the rims and uncut shrunk slots omitted whenever steel foundries will guarantee satisfactory castings. For wheel centers 60 inches in diameter and when the total weight of the engine will permit, the rims should preferably be cast solid without cores so as to obtain the maximum section and have full bearing surface for the tires.

It is difficult to get sufficient counterbalance in centers smaller than 60 inches in diameter so that it will be found very desirable to core out the rims to obtain the maximum lightness on the side next to the crank pin and in some cases on the counterbalance side in order to fill in with lead where necessary.

The American Master Mechanics' Association recommends a rim section as shown in [Fig. 73](#) for wheel centers without retaining rings. The tire is secured from having the center forced through it by a lip on the outside  $\frac{3}{8}$  inch in width and about  $\frac{1}{8}$  inch in height, the tire being left rough at this point. The height of the lip, therefore, depends upon the amount of finishing left on the interior of the tire. Accurate measurements of tires after they have been in service for some time, especially when less than 2-1/2 inches in thickness, show that a rolling out or stretching of the tire occurs, and for reasonably heavy centers, these figures will account more for loose tires than any permanent set in the driving wheel center.



Fig. 73. Section of Rim of Driving Wheel.

*Counterbalance.* A study of the construction of the driving wheel brings up the question of counterbalance since it is made a part of the wheel center. The counterbalance, [Fig. 72](#), is the weight or mass of metal placed in the driving wheel opposite the crank to balance the revolving and reciprocating weights.

The revolving weights to be balanced are the crank pin complete, the back end of the main rod or connecting rod, and each end of each side rod complete. The sum of the weights so found which are attached to each crank pin is the revolving weight for that pin.

The reciprocating weights to be balanced consist of the weight of the piston complete with packing rings, piston rod, crosshead complete, and the front end of the main rod complete. The weight of the rod should be obtained by weighing in a horizontal position after having been placed on centers.

The revolving weights can be counterbalanced by weights attached to the wheel to which they belong, while the reciprocating weights can only be balanced in one direction by adding weights to the driving wheels as all weights added after the revolving parts are balanced overbalance the wheel vertically exactly to the same extent that they tend to balance the reciprocating parts horizontally. This overbalance exerts a sudden pressure or hammer blow upon the rail directly proportional to its weight and to the square of its velocity. At high speeds, this pressure, which is added to the weight of the driver on the rail, may become great enough to injure the track and bridges.

The best form of counterbalance is that of a crescent shape which has its center of gravity the farthest distance possible from the center of the axle. The counterbalance should be placed opposite the crank pin as close to the rods as proper clearance will allow. The clearance should be not less than 3/4 inch. No deficiency of weight in any wheel should be transferred to another. All counter balance blocks should be cast solid. When it is impossible to obtain a correct balance for solid blocks, they may be cored out and filled with lead, which will increase their weight. In all such cases the cavities must be as smooth as possible. Holes should be drilled through the inside face of the wheel to facilitate the removal of the core sand.

In counterbalancing a locomotive, the following fundamental principles should be kept in mind:

1. The weight of the reciprocating parts, which is left unbalanced, should be as great as possible, consistent with a good riding and smooth working engine.
2. The unbalanced weight of the reciprocating parts of all engines for similar service should be proportional to the total weight of the engine in working order.
3. The total pressure of the wheel upon the rail at maximum speed when the counterbalance is down, should not exceed an amount dependent upon the construction of bridges, weight of rail, etc.
4. When the counterbalance is on the upper part of the wheel, the centrifugal force should never be sufficient to lift the wheel from the rail.

The following rules have been generally accepted for the counterbalancing of locomotive drive wheels:

1. Divide the total weight of the engine by 400, subtract the quotient from the weight of the reciprocating parts on one side including the front end of the main rod.
2. Distribute the remainder equally among all driving wheels on one side, adding to it the sum of the weights of the revolving parts for each wheel on that side. The sum for each wheel if placed at a distance from the driving wheel center, equal to the length of the crank, or at a proportionately less weight if at a greater distance, will be the counterbalance weight required.

The method of adjusting the counterbalance in the shop is as follows: After the wheels have been mounted on the axle and the crank pins put in place, the wheels are placed upon trestles as illustrated in [Fig. 74](#). These trestles are provided with perfectly level straight edges upon which the journals rest. A weight pan is suspended from the crank pin as shown. In this pan is placed weight enough to just balance the wheels in such a position that a horizontal line will pass through the center of the axle and crank pin and counterbalance on one wheel, and a vertical line will pass through the axle and crank pin centers of the other side, the crank being above. The amount of weight thus applied, including the pan and the wire by which it is suspended, gives the equivalent counterbalance at crank radius available for balancing the parts. This weight found must not exceed that found to be necessary by the formula. Should the counterbalance be left with extra thickness, the extra weight can be turned off with little trouble after the trial described has been completed. This process should be repeated for the opposite side.

The weight of the reciprocating parts should be kept as low as possible, consistent with good design. Locomotives with rods disconnected and removed should not be handled in